

# APPOLO STUDY CENTRE

## PHYSICS TEST - 6

11 <sup>th</sup> Chemistry	Unit 2	Quantum Mechanical Model of Atom
	Unit 3	Periodic Classification of Elements
11 <sup>th</sup> Chemistry	Unit 9	Solutions
	Unit 10	Chemical bonding
	Unit 15	Environmental Chemistry

### Lesson 2 - Quantum Mechanical Model of Atom

**Erwin Schrodinger**  
(1887 - 1961)

Erwin Schrodinger was awarded the Nobel Prize in physics in 1933 for “ the discovery of new productive forms of atomic theory”. Schrodinger had wide interests starting from chemistry, physics, maths and botany. He was not satisfied with the quantum condition in Bohr's orbit theory and believed that atomic spectra should really be determined by some kind of eigenvalue problem and proposed the wave equation, now named after him.

#### Introduction to atom models:

Let us recall the history of the development of atomic models from the previous classes. We know that all things are made of matter. The basic unit that makes up all matter is atom.

The word ‘atom’ has been derived from the Greek word ‘a-tomio’ meaning non-divisible. Atom was considered as non-divisible until the discovery of subatomic particles such as electron, proton and neutron. J. J. Thomson’s cathode ray experiment revealed that atoms consist of negatively charged particles called electrons. He proposed that atom is a positively charged sphere in which the electrons are embedded like the seeds in the watermelon. Later, Rutherford’s  $\alpha$ -ray scattering experiment results proved that Thomson’s model was wrong.

Rutherford bombarded a thin gold foil with a stream of fast moving  $\alpha$ -particles. It was observed that

- a) most of the  $\alpha$ -particles passed through the foil
- b) some of them were deflected through a small angle and
- c) very few  $\alpha$ -particles were reflected back by  $180^\circ$

### Rutherford's $\alpha$ -ray scattering experiment

Based on these observations, he proposed that in an atom there is a tiny positively charged nucleus and the electrons are moving around the nucleus with high speed. The theory of electromagnetic radiation states that a moving charged particle should continuously lose its energy in the form of radiation. Therefore, the moving electron in an atom should continuously lose its energy and finally collide with nucleus resulting in the collapse of the atom. However, this doesn't happen and the atoms are stable. Moreover, this model does not explain the distribution of electrons around the nucleus and their energies.

### Bohr atom model:

The work of Planck and Einstein showed that the energy of electromagnetic radiation is quantised in units of  $h\nu$  (where  $\nu$  is the frequency of radiation and  $h$  is Planck's constant  $6.626 \times 10^{-34}$  Js). Extending Planck's quantum hypothesis to the energies of atoms, Niels Bohr proposed a new atomic model for the hydrogen atom. This model is based on the following assumptions:

1. The energies of electrons in an atom are quantised.
2. The electron is revolving around the nucleus in a certain circular path of fixed energy called stationary orbit.
3. Electron can revolve only in those orbits in which the angular momentum ( $mvr$ ) of the electron must be equal to an integral multiple of  $h/2\pi$ .

$$\text{i.e. } mvr = nh/2\pi \text{ ----- (1)}$$

where  $n = 1, 2, 3, \dots \text{etc.}$ ,

4. As long as an electron revolves in the fixed stationary orbit, it doesn't lose its energy. However, when an electron jumps from higher energy state ( $E_2$ ) to a lower energy state ( $E_1$ ), the excess energy is emitted as radiation. The frequency of the emitted radiation is

$$E_2 - E_1 = h\nu$$

and

$$\nu = \frac{(E_2 - E_1)}{h} \text{ ----- (2)}$$

Conversely, when suitable energy is supplied to an electron, it will jump from lower energy orbit to a higher energy orbit.

Applying Bohr's postulates to a hydrogen like atom (one electron species such as H, He<sup>+</sup> and Li<sup>2+</sup> etc...) the radius of the nth orbit and the energy of the electron revolving in the nth orbit were derived.

The results are as follows:

$$r_n = \frac{(0.529)n}{z} \text{Å} \text{-----} (3)$$

$$E_n = \frac{(-13.6)z^2}{n^2} \text{eV atom}^{-1} \text{-----} (4)$$

(or)

$$E_n = \frac{(-1312.8)z^2}{n^2} \text{kJ mol}^{-1} \text{-----} (5)$$

The detailed derivation of  $r_n$  and  $E_n$  will be discussed in 12th standard atomic physics unit.

### Limitation of Bohr's atom model

The Bohr's atom model is applicable only to species having one electron such as hydrogen, Li<sup>2+</sup> etc... and not applicable to multi electron atoms. It was unable to explain the splitting of spectral lines in the presence of magnetic field (Zeeman effect) or an electric field (Stark effect). Bohr's theory was unable to explain why the electron is restricted to revolve around the nucleus in a fixed orbit in which the angular momentum of the electron is equal to  $nh/2\pi$  and a logical answer for this, was provided by Louis de Broglie.

### Wave particle duality of matter

Albert Einstein proposed that light has dual nature. i.e. light photons behave both like a particle and as a wave. Louis de Broglie extended this concept and proposed that all forms of matter showed dual character. To quantify this relation, he derived an equation for the wavelength of a matter wave. He combined the following two equations of energy of which one represents wave character ( $h\nu$ ) and the other represents the particle nature ( $mc^2$ ).

- i. Planck's quantum hypothesis

$$E = h\nu \text{-----} (6)$$

- ii. Einstein's mass-energy relationship

$$E = mc^2 \text{-----(7)}$$

From (6) and (7)

$$h\nu = mc^2$$

$$\frac{hc}{\lambda} = mc^2$$

$$\lambda = h/mc \text{-----(8)}$$

The equation (8) represents the wavelength of photons whose momentum is given by  $mc$  (Photons have zero rest mass)

For a particle of matter with mass  $m$  and moving with a velocity  $v$ , the equation (8) can be written as

$$\lambda = h/mv \text{----- (9)}$$

This is valid only when the particle travels at speeds much less than the speed of Light.

This equation implies that a moving particle can be considered as a wave and a wave can exhibit the properties (i.e momentum) of a particle. For a particle with high linear momentum ( $mv$ ) the wavelength will be so small and cannot be observed. For a microscopic particle such as an electron, the mass is of the order of  $10^{-31}kg$ , hence the wavelength is much larger than the size of atom and it becomes significant.

Let us understand this by calculating de Broglie wavelength in the following two cases:

- (i) A 6.626 kg iron ball moving at  $10 \text{ ms}^{-1}$
- (ii) An electron moving at  $72.73 \text{ ms}^{-1}$

$$\lambda_{\text{ironball}} = h/mv$$

$$= \frac{6.626 \times 10^{-32} \text{ kgms}^{-1}}{6.626 \text{ kg} \times 10 \text{ ms}^{-1}} = 1 \times 10^{-35} \text{ m}$$

$$\lambda_{\text{electron}} = h/mv$$

$$= \frac{6.626 \times 10^{-34} \text{ kgm}^2 \text{ s}^{-1}}{9.11 \times 10^{-31} \text{ kg} \times 72.73 \text{ ms}^{-1}}$$

$$= \frac{6.626}{662.6} \times 10^{-3} \text{ m}$$

$$= 1 \times 10^{-5} \text{ m}$$

For the electron, the de Broglie wavelength is significant and measurable while for the iron ball it is too small to measure, hence it becomes insignificant.

### Quantisation of angular momentum and de Broglie concept

According to the de Broglie concept, the electron that revolves around the nucleus exhibits both particle and wave character. In order for the electron wave to exist in phase, the circumference of the orbit should be an integral multiple of the wavelength of the electron wave.

Otherwise, the electron wave is out of phase.

$$\text{Circumference of the orbit} = n\lambda$$

$$2\pi r = n\lambda \text{ -----(10)}$$

$$2\pi r = nh/mv$$

Rearranging,

$$mvr = nh/2\pi \text{ -----(11)}$$

$$\text{Angular momentum} = nh/2\pi$$

The above equation was already predicted by Bohr. Hence, De Broglie and Bohr's concepts are in agreement with each other.

### Wave nature of electrons in allowed Bohr orbits

## Davison and Germer experiment

The wave nature of electron was experimentally confirmed by Davison and Germer. They allowed the accelerated beam of electrons to fall on a nickel crystal and recorded the diffraction pattern. The resultant diffraction pattern is similar to the x-ray diffraction pattern. The finding of wave nature of electron leads to the development of various experimental techniques such as electron microscope, low energy electron diffraction etc...

## Heisenberg's uncertainty principle

The dual nature of matter imposes a limitation on the simultaneous determination of position and momentum of a microscopic particle. Based on this, Heisenberg arrived at his uncertainty principle, which states that 'It is impossible to accurately determine both the position and the momentum of a microscopic particle simultaneously'. The product of uncertainty (error) in the measurement is expressed as follows.

$$\Delta x \cdot \Delta p \geq h / 4\pi \text{-----(11)}$$

Where,  $\Delta x$  and  $\Delta p$  are uncertainties in determining the position and momentum, respectively. The uncertainty principle has negligible effect for macroscopic objects and becomes significant only for microscopic particles such as electrons. Let us understand this by calculating the uncertainty in the velocity of the electron in hydrogen atom. (Bohr radius of 1st orbit is  $0.529 \text{ \AA}$ ) Assuming that the position of the electron in this orbit is determined with the accuracy of 0.5 % of the radius.

$$\text{Uncertainty in position} = \Delta x$$

$$= \frac{0.5\%}{100\%} \times 0.529 \text{ \AA}$$

$$= \frac{0.5}{100} \times 0.529 \times 10^{-10} \text{ m}$$

$$\Delta x = 2.645 \times 10^{-13} \text{ m}$$

**11<sup>th</sup>vol 1**  
**Unit - 3**  
**Periodic Classification of Elements**

"An awareness of the periodic table is essential to anyone who wishes to disentangle the word and see how it is built up from the fundamental building blocks of the chemistry, the chemical elements "

- Glenn T. Seaborg

Glenn Theodore Seaborg received Nobel Prize in 1951 in chemistry for the discoveries of trans-uranium elements. He was the co-discoverer of plutonium and other trans uranium elements. He along with his colleagues has discovered over a hundred isotopes of other elements. He demonstrated that actinide elements are analogues to rare earth series of lanthanide elements.

**Introduction**

There are millions of chemical compounds existing in nature with different compositions and properties, formed from less than 100 naturally occurring elements.

The discovery of elements is linked with human civilization. In stone age man has used some metals to suit his needs without knowing that they are elements. Soon he learnt to extract elements from ores and fashion them into his daily life. Over the years, more and more elements were discovered. In 1789, Lavoisier from France, published the first list of chemical elements containing 23 elements after several experimental investigations.

Antoine Lavoisier classified the substances into four groups of elements namely acid-making elements, gas-like elements, metallic elements and earthy elements

Lavoisier table

acid-making elements	gas-like elements
Sulphur	Light
Phosphorus	Caloric (heat)
Charcoal (carbon)	Oxygen
	Azote (nitrogen)
	Hydrogen

metallic elements	earthy elements
cobalt, mercury, tin	lime (calcium

	oxide)
copper, nickel, iron	magnesia (magnesium oxide)
gold, lead, silver, zinc	barytes (barium sulphate)
manganese, tungsten	argilla (aluminium oxide)
platina (platinum)	silex (silicon dioxide)

### Classification of Elements

During the 19th century, scientists have isolated several elements and the list of known elements increased. Currently, we have 118 known elements. Out of 118 elements, 92 elements with atomic numbers 1 to 92 are found in nature. Scientists have found out there are some similarities in properties among certain elements. This observation has led to the idea of classification of elements based on their properties. In fact, classification will be beneficial for the effective utilization of these elements. Several attempts were made to classify the elements. However, classification based on the atomic weights led to the construction of a proper form of periodic table.

In 1817, J. W. Dobereiner classified some elements such as chlorine, bromine and iodine with similar chemical properties into the group of three elements called as triads. In triads, the atomic weight of the middle element nearly equal to the arithmetic mean of the atomic weights of the remaining two elements. However, only a limited number of elements can be grouped as triads.

### Dobereiner Triads

S. No.	Elements in the Triad	Atomic weight of middle element	Average atomic weight of the remaining Elements
1.	Li, Na, K	23	$\frac{7 + 39}{2} = 23$
2.	Cl, Br, I	80	$\frac{35.5 + 127}{2} = 81.25$



3.	Ca, Sr, Ba	88	$\frac{40 + 137}{2} = 88.5$
----	------------	----	-----------------------------

This concept can not be extended to some triads which have nearly same atomic masses such as [Fe, Co, Ni], [Ru, Rh, Pd] and [Os, Ir, Pt].

In 1862, A. E. B. de Chancourtois reported a correlation between the properties of the elements and their atomic weights. He said 'the properties of bodies are the properties of numbers'. He intended the term numbers to mean the value of atomic weights. He designed a helix by tracing at an angle 45° to the vertical axis of a cylinder with circumference of 16 units. He arranged the elements in the increasing atomic weights along the helix on the surface of this cylinder. One complete turn of a helix corresponds to an atomic weight increase of 16. Elements which lie on the 16 equidistant vertical lines drawn on the surface of cylinder shows similar properties. This was the first reasonable attempt towards the creation of periodic table. However, it did not attract much attention.

In 1864, J. Newland made an attempt to classify the elements and proposed the law of octaves. On arranging the elements in the increasing order of atomic weights, he observed that the properties of every eighth element are similar to the properties of the first element. This law holds good for lighter elements up to calcium.

#### Newlands' Octaves

<sup>7</sup> Li	<sup>9</sup> Be	<sup>11</sup> B	<sup>12</sup> C	<sup>14</sup> N	<sup>16</sup> O	<sup>19</sup> F
<sup>23</sup> Na	<sup>24</sup> Mg	<sup>27</sup> Al	<sup>29</sup> Si	<sup>31</sup> P	<sup>32</sup> S	<sup>35.5</sup> Cl
<sup>39</sup> K	<sup>40</sup> Ca					

#### Mendeleev's Classification

In 1868, Lothar Meyer had developed a table of the elements that closely resembles the modern periodic table. He plotted the physical properties such as atomic volume, melting point and boiling point against atomic weight and observed a periodical pattern.

During same period Dmitri Mendeleev independently proposed that "the properties of the elements are the periodic functions of their atomic weights" and this is called periodic law. Mendeleev listed the 70 known elements at that time in several vertical columns in order of increasing atomic weights. Thus, Mendeleev constructed the first periodic table based on the periodic law.

As shown in the periodic table, he left some blank spaces since there were no known elements with the appropriate properties at that time. He and others predicted the physical and chemical properties of the missing elements. Eventually these missing elements were discovered and found to have the predicted properties. For example, Gallium (Ga) of group

III and germanium (Ge) of group IV were unknown at that time. But Mendeleev predicted their existence and properties. He referred the predicted elements as eka-aluminium and eka-silicon. After discovery of the actual elements, their properties were found to match closely to those predicted by Mendeleev.

### Properties predicted for Eka-aluminium and Eka-silicon

S. NO.	Property	Ekaaluminium (Predicted)	Gallium (Observed)	Ekasilicon (Predicted)	Germanium (Observed)
1.	Atomic weight	68	70	72	72.59
2.	Density (g/cm <sup>3</sup> )	5.9	5.94	5.5	5.35
3.	Melting point	low	29.78°C	High	947°C
4.	Formula of oxide	E <sub>2</sub> O <sub>3</sub>	Ga <sub>2</sub> O <sub>3</sub>	EO <sub>2</sub>	GeO <sub>2</sub>
5.	Formula of chloride	ECl <sub>3</sub>	GaCl <sub>3</sub>	ECl <sub>4</sub>	GeCl <sub>4</sub>

### Anomalies of Mendeleev's Periodic Table

Some elements with similar properties were placed in different groups and those with dissimilar properties were placed in same group.

Example: Tellurium (127.6) was placed in VI group but Iodine (127.0) was placed in VII group.

Similarly elements with higher atomic weights were placed before lower atomic weights based on their properties in contradiction to his periodic law. Example <sup>59</sup>Co<sub>27</sub> was placed before <sup>58.7</sup>Ni<sub>28</sub>

Series	Group of Elements									
	I	II	III	IV	V	VI	VII	VIII		
1	Hydrogen H 1.008									
2	Helium He 4.0	Beryllium Be 9.1	Boron B 11.0	Carbon C 12.0	Nitrogen N 14.0	Oxygen O 16.0	Fluorine F 19.0			
3	Neon Ne 19.9	Magnesium Mg 24.3	Aluminium Al 27.0	Silicon Si 28.0	Phosphorus P 31.0	Sulphur S 32.0	Chlorine Cl 35.5			
4	Argon Ar 39.9	Calcium Ca 40.1	Scandium Sc 44.1	Titanium Ti 48.1	Vanadium V 51.4	Chromium Cr 52.0	Manganese Mn 55.0			
5		Copper Cu 63.6	Zinc Zn 65.4	Germanium Ge 72.6	Arsenic As 75.0	Selenium Se 79.0	Bromine Br 79.9			
6	Krypton Kr 81.0	Strontium Sr 87.6	Yttrium Y 88.9	Zincium Zn 90.6	Nickel Ni 94.0	Cobalt Co 96.0	Bromine Br 96.0			
7		Calcium Ca 102.9	Indium In 114.0	Mercury Hg 200.6	Antimony Sb 120.0	Tellurium Te 127.6	Iodine I 126.9			
8	Xenon Xe 128	Barium Ba 137.4	Lanthanum La 139	Cerium Ce 140						
9										
10			Yttrium Y 88.9		Tantalum Ta 182	Tungsten W 186				
11		Gold Au 197.2	Mercury Hg 200.6	Thallium Tl 204.4	Lead Pb 207.2	Bismuth Bi 209				
12		Barium Ba 224		Thorium Th 232						
					Higher Soluble Oxides					
	R	R <sub>2</sub> O		RO <sub>2</sub>	R <sub>2</sub> O <sub>3</sub>	RO <sub>3</sub>	RO <sub>4</sub>			RO <sub>4</sub>
				Higher Gaseous Hydrogen Compounds						
				BH <sub>4</sub>	BH <sub>3</sub>	BH <sub>2</sub>				BH <sub>3</sub>

## Moseley's Work and Modern Periodic Law

In 1913, Henry Moseley studied the characteristic X-rays spectra of several elements by bombarding them with high energy electrons and observed a linear correlation between atomic number and the frequency of X-rays emitted which is given by the following expression.

$$\nu = a(Z - b)$$

Where,  $\nu$  is the frequency of the X-rays emitted by the element with atomic number 'Z'; a and b are constants and have same values for all the elements.

The plot of  $\sqrt{\nu}$  against Z gives a straight line. Using this relationship, we can determine the atomic number of an unknown (new) element from the frequency of X-ray emitted.

Based on his work, the modern periodic law was developed which states that, “the physical and chemical properties of the elements are periodic functions of their atomic numbers.” Based on this law, the elements were arranged in order of their increasing atomic numbers. This mode of arrangement reveals an important truth that the elements with similar properties recur after regular intervals. The repetition of physical and chemical properties at regular intervals is called periodicity.

### Modern Periodic Table

The physical and chemical properties of the elements are correlated to the arrangement of electrons in their outermost shell (valence shell). Different elements having similar outer shell electronic configuration possess similar properties. For example, elements having one electron in their valence shell s-orbital possess similar physical and chemical properties. These elements are grouped together in the modern periodic table as first group elements.

#### Electronic configuration of alkali metals (ns<sup>1</sup>)

Elements in Group 1	Atomic number	Number of electrons in various shells in the order K L M N P	Valence shell configuration
Li	3	2,1	2s <sup>1</sup>
Na	11	2,8,1	3s <sup>1</sup>
K	19	2,8,8,1	4s <sup>1</sup>
Rb	37	2,8,18,8,1	5s <sup>1</sup>
Cs	55	2,8,18,18,8,1	6s <sup>1</sup>
Fr	87	2,8,18,32,18,1	7s <sup>1</sup>

Similarly, all the elements are arranged in the modern periodic table which contains 18 vertical columns and 7 horizontal rows. The vertical columns are called groups and the horizontal rows are called periods. Groups are numbered 1 to 18 in accordance with the IUPAC recommendation which replaces the old numbering scheme IA to VIIA, IB to VIIB and VIII.

Each period starts with the element having general outer electronic configuration  $ns^1$  and ends with  $np^6$ . Here 'n' corresponds to the period number (principal quantum number). The aufbau principle and the electronic configuration of atoms provide a theoretical foundation for the modern periodic table.

### Nomenclature of Elements with Atomic Number Greater than 100

Usually, when a new element is discovered, the discoverer suggests a name following IUPAC guidelines which will be approved after a public opinion. In the meantime, the new element will be called by a temporary name coined using the following IUPAC rules, until the IUPAC recognises the new name.

1. The name was derived directly from the atomic number of the new element using the following numerical roots.

#### Notation for IUPAC Nomenclature of elements

Digital	0	1	2	3	4	5	6	7	8	9
Root	Nil	Un	Bi	Tri	Quad	Pent	Hex	Sept	Oct	enn
Abbreviation	N	U	B	T	Q	P	H	S	O	e

2. The numerical roots corresponding to the atomic number are put together and 'ium' is added as suffix
3. The final 'n' of 'enn' is omitted when it is written before 'nil' (enn + nil = enil) similarly the final 'i' of 'bi' and 'tri' is omitted when it is written before 'ium' (bi + ium = bium; tri + ium = trium)
4. The symbol of the new element is derived from the first letter of the numerical roots.

The following table illustrates these facts.

#### Name of elements with atomic number above 100

Atomic number	Temp. Name	Temp. Symbol	Name of the element	Symbol
101	Unnilunium	Unu	Mendelevium	Md
102	Unnilbium	Unb	Nobelium	No
103	Unniltrium	Unt	Lawrencium	Lr

104	Unnilquadium	Unq	Rutherfordium	Rf
105	Unnilpentium	Unp	Dubnium	Db
106	Unnilhexium	Unh	Seaborgium	Sg
107	Unnilseptium	Uns	Bohrium	Bh
108	Unniloctium	Uno	Hassium	Hs
109	Unnilennium	Une	Meitnerium	Mt
110	Ununnilium	Unn	Darmstadtium	Ds
111	Ununnilium	Uuu	Roentgenium	Rg
112	Ununbium	Uub	Copernicium	Cn
113	Ununtrium	Uut	Nihonium	Nh
114	Ununquadium	Uup	Flerovium	Lv
115	Ununpentium	Uup	Moscovium	Ts
116	Ununhexium	Uuh	Livermorium	Lv
117	Ununseptium	Uus	Tennessine	Ts
118	Ununoctium	Uco	Oganesson	Og

### Grouping of Elements based on Electronic Configurations

In the modern periodic table, the elements are organised in 7 periods and 18 groups based on the modern periodic law. The placement of element in the periodic table is closely related to its outer shell electronic configuration. Let us analyse the change in the electronic configuration of elements along the periods and down the groups.

### Variation of Electronic Configuration along the periods

We have already learnt that each period starts with the element having general outer electronic configuration  $ns^1$  and ends with  $ns^2, np^6$  where  $n$  is the period number. The first period starts with the filling of valence electrons in  $1s$  orbital, which can accommodate only two electrons. Hence, the first period has two elements, namely hydrogen and helium. The second period starts with the filling of valence electrons in  $2s$  orbital followed by three  $2p$  orbitals with eight elements from lithium to neon. The third period starts with filling of valence electrons in the  $3s$  orbital followed by  $3p$  orbitals. The fourth period starts with filling of valence electrons from  $4s$  orbital followed by  $3d$  and  $4p$  orbitals in accordance with

Aufbau principle. Similarly, we can explain the electronic configuration of elements in the subsequent periods.

**Table 3.10 Electronic configuration of elements in a period**

Period number (n)	Filling of electrons in orbitals		Number of elements	Outer shell Electronic configuration	
	Starts from	Ends with		First element	Last element
1	1s	1s	2	H - 1s <sup>1</sup>	He - 1s <sup>2</sup>
2	2s	2p	8	Li - 2s <sup>1</sup>	Ar - 2s <sup>2</sup> 2p <sup>6</sup>
3	3s	3p	8	Na - 3s <sup>1</sup>	Ne - 3s <sup>2</sup> 3p <sup>6</sup>
4	4s	3d → 4p	18	K - 4s <sup>1</sup>	Kr - 4s <sup>2</sup> 4p <sup>6</sup>
5	5s	4d → 5p	18	Rb - 5s <sup>1</sup>	Xe - 5s <sup>2</sup> 5p <sup>6</sup>
6	6s	4f → 5d → 6p	32	Cs - 6s <sup>1</sup>	Rn - 6s <sup>2</sup> 6p <sup>6</sup>
7	7s	5f → 6d → 7p	32	Fr - 7s <sup>1</sup>	Og - 7s <sup>2</sup> 7p <sup>6</sup>

In the fourth period the filling of 3d orbitals starts with scandium and ends with zinc. These 10 elements are called first transition series. Similarly 4d, 5d and 6d orbitals are filled in successive periods and the corresponding series of elements are called second, third and fourth transition series respectively.

In the sixth period the filling of valence electrons starts with 6s orbital followed by 4f, 5d and 6p orbitals. The filling up of 4f orbitals begins with Cerium (Z=58) and ends at Lutetium (Z=71). These 14 elements constitute the first inner-transition series called Lanthanides. Similarly, in the seventh period 5f orbitals are filled, and it's -14 elements constitute the second inner-transition series called Actinides. These two series are placed separately at the bottom of the modern periodic table.

### Variation of Electronic Configuration in the Groups:

Elements of a group have similar electronic configuration in the outer shell. The general outer electronic configurations for the 18 groups are listed in the Table 3.11. The groups can be combined as s, p, d and f block elements on the basis of the orbital in which the last valence electron enters.

The elements of group 1 and group 2 are called s-block elements, since the last valence electron enters the ns orbital. The group 1 elements are called alkali metals while the group 2 elements are called alkaline earth metals. These are soft metals and possess low melting and boiling points with low ionisation enthalpies. They are highly reactive and form ionic compounds. They are highly electropositive in nature and most of the elements imparts colour to the flame. We will study the properties of these group elements in detail in subsequent chapters.

The elements of groups 13 to 18 are called p-block elements or representative elements and have a general electronic configuration ns<sup>2</sup>, np<sup>1-6</sup>. The elements of the group 16 and 17 are called chalcogens and halogens respectively. The elements of 18<sup>th</sup> group contain

completely filled valence shell electronic configuration ( $ns^2, np^6$ ) and are called inert gases or noble gases. The elements of p-block have high negative electron gain enthalpies. The ionisation energies are higher than that of s-block elements. They form mostly covalent compounds and shows more than one oxidation states in their compounds.

The elements of the groups 3 to 12 are called d-block elements or transition elements with general valence shell electronic configuration  $ns^{1-2}, (n-1)d^{1-10}$ . These elements also show more than one oxidation state and form ionic, covalent and co-ordination compounds. They can form interstitial compounds and alloys which can also act as catalysts. These elements have high melting points and are good conductors of heat and electricity.

The lanthanides ( $4f^{1-14}, 5d^{0-1}, 6s^2$ ) and the actinides ( $5f^{0-14}, 6d^{0-1}, 7s^2$ ) are called f-block elements. These elements are metallic in nature and have high melting points. Their compounds are mostly coloured. These elements also show variable oxidation states.

**Table 3.11 General outer electronic configuration of elements in groups:**

1	2	3	4	5	6	7	8	9	10	11	12	13	14	15	16	17	18
$ns^1$	$ns^2$	$ns^2(n-1)d^1$	$ns^2(n-1)d^2$	$ns^2(n-1)d^5$	$ns^1(n-1)d^5$	$ns^2(n-1)d^5$	$ns^2(n-1)d^6$	$ns^2(n-1)d^7$	$ns^2(n-1)d^8$	$ns^1(n-1)d^{10}$	$ns^2(n-1)d^{10}$	$ns^2 np^1$	$ns^2 np^2$	$ns^2 np^3$	$ns^2 np^4$	$ns^2 np^5$	$ns^2 np^6$
s Block elements		d-Block elements										p-Block elements					
f block elements		Lanthanides $4f^{1-14} 5d^{0-1} 6s^2$															
		Actinides $5f^{0-14} 6d^{0-2} 7s^2$															

## Periodic Trends in Properties

As discussed earlier, the electronic configuration of the elements shows a periodic variation with increase in atomic numbers. Similarly a periodic trend is observed in physical and chemical behaviour of elements. In this section, we will study the periodic trends in the following properties of elements.

1. Atomic radius
2. Ionic radius
3. Ionisation enthalpy (energy)
4. Electron gain enthalpy (electron affinity)
5. Electronegativity

### Atomic radius

Atomic radius of an atom is defined as the distance between the centre of its nucleus and the outermost shell containing the valence electron.



It is not possible to measure the radius of an isolated atom directly. Except for noble gases, usually atomic radius is referred to as covalent radius or metallic radius depending upon the nature of bonding between the concerned atoms.

### Covalent radius

It is one-half of the internuclear distance between two identical atoms linked together by a single covalent bond. Inter nuclear distance can be determined using x-ray diffraction studies.

#### Example:

The experimental internuclear distance in Cl<sub>2</sub> molecule is 1.98 Å. The covalent radius of chlorine is calculated as below.

$$\begin{aligned}
 d_{Cl-Cl} &= r_{Cl} + r_{Cl} \\
 \Rightarrow d_{Cl-Cl} &= 2r_{Cl} \\
 \Rightarrow r_{Cl} &= \frac{d_{Cl-Cl}}{2} \\
 &= \frac{1.98}{2} = 0.99 \text{ \AA}
 \end{aligned}$$

The covalent radius of chlorine =  $\frac{198}{2} \text{ pm}$   
 = 99 pm

The formation of covalent bond involves the overlapping of atomic orbitals and it reduces the expected internuclear distance. Therefore covalent radius is always shorter than the actual atomic radius.

The covalent radius of individual atom can also be calculated using the internuclear distance ( $d_{A-B}$ ) between two different atoms A and B. The simplest method proposed by Schomaker and Stevenson is as follows.

$$d_{A-B} = r_A + r_B - 0.09(\chi_A - \chi_B)$$

where  $\chi_A$  and  $\chi_B$  are the electronegativities of A and B respectively in Pauling units. Here  $\chi_A > \chi_B$  and radius is in Å.

Let us calculate the covalent radius of hydrogen using the experimental dH-Cl value is 1.28 Å and the covalent radius of chlorine is 0.99 Å. In Pauling scale the electronegativity of chlorine and hydrogen are 3 and 2.1 respectively.

$$d_{\text{H-Cl}} = r_{\text{H}} + r_{\text{Cl}} - 0.09 (\chi_{\text{Cl}} - \chi_{\text{H}})$$

$$1.28 = r_{\text{H}} + 0.09 - 0.09 (3 - 2.1)$$

$$1.28 = r_{\text{H}} + 0.09 - 0.09 (0.9)$$

$$1.28 = r_{\text{H}} + 0.09 - 0.081$$

$$1.28 = r_{\text{H}} + 0.909$$

$$\therefore r_{\text{H}} = 1.28 - 0.909 = 0.317 \text{ \AA}$$

### Metallic radius

It is defined as one-half of the distance between two adjacent metal atoms in the closely packed metallic crystal lattice.

For example, the distance between the adjacent copper atoms in solid copper is 2.56 Å and therefore the metallic radius of copper is

$$\frac{2.56}{2} = 1.28 \text{ \AA}$$

The metallic radius can be calculated using the unit cell length of the metallic crystal. You will study the detailed calculation procedure in XII standard solid state unit.

### Periodic Trends in Atomic Radius

#### Variation in Periods

Atomic radius tends to decrease in a period. As we move from left to right along a period, the valence electrons are added to the same shell. The simultaneous addition of protons to the nucleus, increases the nuclear charge, as well as the electrostatic attractive force between the valence electrons and the nucleus. Therefore atomic radius decreases along a period.

#### Effective nuclear charge

In addition to the electrostatic forces of attraction between the nucleus and the electrons, there exists repulsive forces among the electrons. The repulsive force between the inner shell electrons and the valence electrons leads to a decrease in the electrostatic attractive forces acting on the valence electrons by the nucleus. Thus, the inner shell electrons act as a shield between the nucleus and the valence electrons. This effect is called shielding effect.

The net nuclear charge experienced by valence electrons in the outermost shell is called the effective nuclear charge. It is approximated by the below mentioned equation.

$$Z_{\text{eff}} = Z - S$$

Where Z is the atomic number and 'S' is the screening constant which can be calculated using Slater's rules as described below.

### Step 1:

Write the electronic configuration of the atom and rearrange it by grouping ns and np orbitals together and others separately in the following form. (1s) (2s, 2p) (3s, 3p) (3d) (4s, 4p) (4d) (4f) (5s, 5p)...

### Step 2:

Identify the group in which the electron of interest is present. The electron present right to this group does not contribute to the shielding effect.

Each of the electrons within the identified group (denoted by 'n') shields to an extent of 0.35 unit of nuclear charge. However, it is 0.30 unit for 1s electron.

### Step 3 :

Shielding of inner shell electrons.

If the electron of interest belongs to either s or p orbital,

- i) each electron within the (n-1) group shields to an extent of 0.85 unit of nuclear charge, and
- ii) each electron within the (n-2) group (or) even lesser group (n-3, (n-4) etc... completely shields i.e. to an extent of 1.00 unit of nuclear charge. If the electron of interest belongs to d or f orbital, then each of electron left of the group of electron of interest shields to an extent of 1.00 unit of nuclear charge.

### Step 4 :

Summation of the shielding effect of all the electrons gives the shielding constant 'S'

**Example:** Let us explain the calculation of effective nuclear charge on 4s electron and 3d electron in scandium. The electronic configuration of scandium is  $1s^2, 2s^2, 2p^6, 3s^2, 3p^6, 4s^2, 3d^1$ . we can rearrange as below.

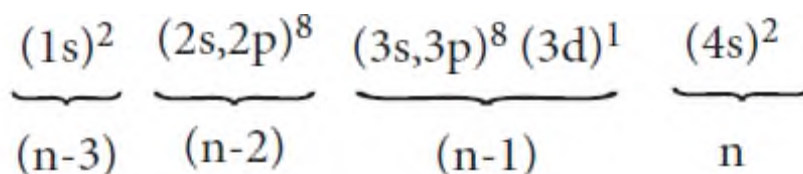

Group	number of electron in the group	contribution of each electron to 'S' value	contribution of a particular group to electrons to 'S' value
(n)	1	0.35	0.35

(n-1)	9	0.85	7.65
(n-2) & others	10	1	10.00
S value			18.00

$$Z_{\text{eff}} = Z - S \text{ i.e.} = 21 - 18 \therefore Z_{\text{eff}} = 3$$

### Calculation of effective nuclear charge on 3d electron

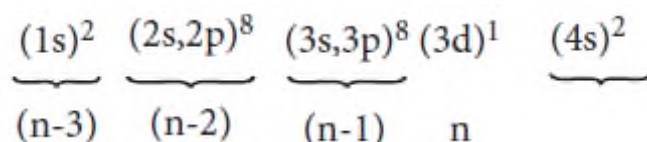

Group	number of electron in the group	contribution of each electron to 'S' value	contribution of a particular group to electrons to 'S' value
n	0	0.35	0
(n-1) & others	18	1	18
S Value			18

$$\therefore Z_{\text{eff}} = Z - S \text{ i.e.} = 21 - 18 \therefore Z_{\text{eff}} = 3$$

### Shielding effect from inner shell electrons (Slater's rules)

Electron Group	Electron of interest either S or P	Electron of interest either d or f
n	0.35 (0.30 for (S electron))	0.35
(n-1)	0.85	1.00
(n-2) and others	1.00	1.00

Atomic radius (covalent radius) of second period elements.

Elements	Effective nuclear	Covalent radius
----------	-------------------	-----------------

	charge	(pm)
Li <sup>3</sup>	1.30	167
Be <sup>4</sup>	1.95	112
C <sup>6</sup>	2.60	87
N <sup>7</sup>	3.25	67
O <sup>8</sup>	3.25	56
F <sup>9</sup>	4.55	48
Ne <sup>10</sup>	5.85	38

### Variation in Group

In the periodic table, the atomic radius of elements increases down the group. As we move down a group, new shells are opened to accommodate the newly added valence electrons. As a result, the distance between the centre of the nucleus and the outermost shell containing the valence electron increases. Hence, the atomic radius increases. The trend in the variation of the atomic radius of the alkali metals down the group is shown below.

Variation of covalent radius of group 1 elements

Element	Outermost shell containing valence electron	Covalent radius (Å)
Li	L (n=2)	1.35
Na	M (n=3)	1.54
K	N (n=4)	1.96
Rb	O (n=5)	2.11
Cs	P(n=6)	2.25

### Ionic radius

It is defined as the distance from the centre of the nucleus of the ion up to which it exerts its influence on the electron cloud of the ion. Ionic radius of uni-univalent crystal can be calculated using Pauling's method from the inter ionic distance between the nuclei of the

cation and anion. Pauling assumed that ions present in a crystal lattice are perfect spheres, and they are in contact with each other therefore,

Where  $d$  is the distance between the centre of the nucleus of cation  $C^+$  and anion  $A^-$  and  $r_{C^+}$ ,  $r_{A^-}$  are the radius of the cation and anion respectively.

Pauling also assumed that the radius of the ion having noble gas electronic configuration ( $Na^+$  and  $Cl^-$  having  $1s^2 2s^2, 2p^6$  configuration) is inversely proportional to the effective nuclear charge felt at the periphery of the ion.

$$i.e. r_{C^+} \propto \frac{1}{(Z_{eff})_{C^+}} \dots\dots\dots(1)$$

$$r_{A^-} \propto \frac{1}{(Z_{eff})_{A^-}} \dots\dots\dots(3)$$

Where  $Z_{eff}$  is the effective nuclear charge and  $Z_{eff} = Z - S$

Dividing the equation 1 by 3

$$\frac{r_{C^+}}{r_{A^-}} = \frac{(Z_{eff})_{A^-}}{(Z_{eff})_{C^+}} \dots\dots\dots(4)$$

On solving equation (1) and (4) the values of  $r_{C^+}$  and  $r_{A^-}$  can be obtained

Let us explain this method by calculating the ionic radii of  $Na^+$  and  $F^-$  in  $NaF$  crystal whose interionic distance is equal to 231 pm .

$$d = r_{Na^+} + r_{F^-} \dots\dots\dots(5)$$

$$i.e. r_{Na^+} + r_{F^-} = 231 pm$$

we know that

$$\frac{r_{Na^+}}{r_{F^-}} = \frac{(Z_{eff})_{F^-}}{(Z_{eff})_{Na^+}}$$

$$(Z_{eff})_{F^-} = Z - S$$

$$= 9 - 4.15$$

$$= 4.85$$

$$(Z_{eff})_{Na^+} = 11 - 4.15$$

$$= 6.85$$

$$\therefore \frac{r_{Na^+}}{r_{F^-}} = \frac{4.85}{6.85}$$

$$= 0.71$$

$$\Rightarrow r_{Na^+} = 0.71 \times r_{F^-}$$

Substituting (3) in (1)

$$(1) \Rightarrow 0.71r_{F^-} + r_{F^-} = 231 pm$$

$$1.71r_{F^-} = 231 pm$$

$$r_{F^-} = \frac{231}{1.71} = 135.1 pm$$

Substituting the value of  $r_{F^-}$  in equation (1)

$$r_{Na^+} + 135.1 = 231$$

$$r_{Na^+} = 95.9 pm$$

### Ionisation energy

It is defined as the minimum amount of energy required to remove the most loosely bound electron from the valence shell of the isolated neutral gaseous atom in its ground state. It is expressed in  $\text{kJ mol}^{-1}$  or in electron volts (eV).

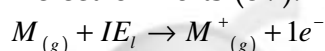

Where  $IE_1$  represents the first ionisation energy.

### Successive Ionisation energies

The minimum amount of energy required to remove an electron from a unipositively charged cation is called second ionisation energy. It is represented by the following equation.

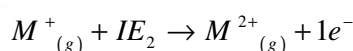

In this way we can define the successive ionisation energies such as third, fourth etc.

The total number of electrons are less in the cation than the neutral atom while the nuclear charge remains the same. Therefore the effective nuclear charge of the cation is higher than the corresponding neutral atom. Thus the successive ionisation energies, always increase in the following order

$$IE_1 < IE_2 < IE_3 < \dots$$

### Periodic Trends in Ionisation Energy

The ionisation energy usually increases along a period with few exceptions. As discussed earlier, when we move from left to right along a period, the valence electrons are added to the same shell, at the same time protons are added to the nucleus. This successive increase of nuclear charge increases the electrostatic attractive force on the valence electron

and more energy is required to remove the valence electron resulting in high ionisation energy.

Let us consider the variation in ionisation energy of second period elements. The plot of atomic number vs ionisation energy is given below.

In the following graph, there are two deviation in the trends of ionisation energy. It is expected that boron has higher ionisation energy than beryllium since it has higher nuclear charge. However, the actual ionisation energies of beryllium and boron are 899 and 800 kJ mol<sup>-1</sup> respectively contrary to the expectation. It is due to the fact that beryllium with completely filled 2s orbital, is more stable than partially filled valence shell electronic configuration of boron. (2s<sup>2</sup>, 2p<sup>1</sup>)

The electronic configuration of beryllium (Z=4) in its ground state is 1s<sup>2</sup>, 2s<sup>2</sup> and that of boron (Z = 5) 1s<sup>2</sup> 2s<sup>2</sup> 2p<sup>1</sup>

Similarly, nitrogen with 1s<sup>2</sup>, 2s<sup>2</sup>, 2p<sup>3</sup> electronic configuration has higher ionisation energy (1402 kJ mol<sup>-1</sup>) than oxygen (1314 kJ mol<sup>-1</sup>). Since the half filled electronic configuration is more stable, it requires higher energy to remove an electron from 2p orbital of nitrogen. Whereas the removal one 2p electron from oxygen leads to a stable half filled configuration. This makes comparatively easier to remove 2p electron from oxygen.

### Periodic variation in group

The ionisation energy decreases down a group. As we move down a group, the valence electron occupies new shells, the distance between the nucleus and the valence electron increases. So, the nuclear forces of attraction on valence electron decreases and hence ionisation energy also decreases down a group.

### Ionisation energy and shielding effect

As we move down a group, the number of inner shell electron increases which in turn increases the repulsive force exerted by them on the valence electrons, i.e. the increased shielding effect caused by the inner electrons decreases the attractive force acting on the valence electron by the nucleus. Therefore the ionisation energy decreases.

Let us understand this trend by considering the ionisation energy of alkali metals.

### Electron affinity

It is defined as the amount of energy released (required in the case noble gases) when an electron is added to the valence shell of an isolated neutral gaseous atom in its ground state to form its anion. It is expressed in kJ mol<sup>-1</sup>

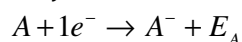

### Variation of Electron Affinity in a period:



The variation of electron affinity is not as systematic as in the case of ionisation energy. As we move from alkali metals to halogens in a period, generally electron affinity increases, i.e. the amount of energy released will be more. This is due to an increase in the nuclear charge and decrease in size of the atoms. However, in case of elements such as beryllium ( $1s^2, 2s^2$ ), nitrogen ( $1s^2, 2s^2, 2p^3$ ) the addition of extra electron will disturb their stable electronic configuration and they have almost zero electron affinity.

### Variation of electron affinity (electron gain energy) along I period

Noble gases have stable  $ns^2, np^6$  configuration, and the addition of further electron is unfavourable and requires energy. Halogens having the general electronic configuration of  $ns^2, np^5$  readily accept an electron to get the stable noble gas electronic configuration ( $ns^2, np^6$ ), and therefore in each period the halogen has high electron affinity. (high negative values)

### Variation of Electron affinity in a group:

As we move down a group, generally the electron affinity decreases. It is due to increase in atomic size and the shielding effect of inner shell electrons. However, oxygen and fluorine have lower affinity than sulphur and chlorine respectively. The sizes of oxygen and fluorine atoms are comparatively small and they have high electron density. Moreover, the extra electron added to oxygen and fluorine has to be accommodated in the 2p orbital which is relatively compact compared to the 3p orbital of sulphur and chlorine so, oxygen and fluorine have lower electron affinity than their respective group elements sulphur and chlorine.

### Electronegativity

It is defined as the relative tendency of an element present in a covalently bonded molecule, to attract the shared pair of electrons towards itself.

Electronegativity is not a measurable quantity. However, a number of scales are available to calculate its value. One such method was developed by Pauling, he assigned arbitrary value of electronegativities for hydrogen and fluorine as 2.2 and 4.0 respectively. Based on this the electronegativity values for other elements can be calculated using the following expression

$$(X_A - X_B) = 0.182\sqrt{E_{AB} - (E_{AA} * E_{BB})}^{1/2}$$

Where  $E_{AB}$ ,  $E_{AA}$  and  $E_{BB}$  are the bond dissociation energies of AB,  $A_2$  and  $B_2$  molecules respectively.

The electronegativity of any given element is not a constant and its value depends on the element to which it is covalently bound. The electronegativity values play an important role in predicting the nature of the bond.

### Variation of Electronegativity in a period:

The electronegativity generally increases across a period from left to right. As discussed earlier, the atomic radius decreases in a period, as the attraction between the valence electron and the nucleus increases. Hence the tendency to attract shared pair of electrons increases. Therefore, electronegativity also increases in a period.

Paulings scale of electronegativity value of elements



### Variation of Electronegativity in a group:

The electronegativity generally decreases down a group. As we move down a group the atomic radius increases and the nuclear attractive force on the valence electron decreases. Hence, the electronegativity decreases.

Noble gases are assigned zero electronegativity. The electronegativity values of the elements of s-block show the expected decreasing order in a group. Except 13th and 14th group all other p-block elements follow the expected decreasing trend in electronegativity.

### Periodic Trends in Chemical Properties:

So far, we have studied the periodicity of the physical properties such as atomic radius, ionisation enthalpy, electron gain enthalpy and electronegativity. In addition, the chemical properties such as reactivity, valence, oxidation state etc... also show periodicity to certain extent.

In this section, we will discuss briefly about the periodicity in valence (oxidation state) and anomalous behaviour of second period elements (diagonal relationship).

### Valence or Oxidation States

The valence of an atom is the combining capacity relative to hydrogen atom. It is usually equal to the total number of electrons in the valence shell or equal to eight minus the number of valence electrons. It is more convenient to use oxidation state in the place of valence.

### Periodicity of Valence or Oxidation States

The valence of an atom primarily depends on the number of electrons in the valence shell. As the number of valence electrons remains same for the elements in same group, the maximum valence also remains the same. However, in a period the number of valence electrons increases, hence the valence also increases.

#### Variation of valence in groups

Alkali Metals (Group 1)			Group 15		
Element	No. of electrons in valence shell	Valence	Element	No. of electrons in valence shell	Valence
Li	1	1	N	5	3,5
Na	1	1	P	5	3,5
K	1	1	As	5	3,5
Rb	1	1	Sb	5	3,5
Cs	1	1	Bi	5	3,5
Fr	1	1			

#### Variation of valence in period (1st period)

Element	Li	Be	B	C	N	O	F	Ne
No. of electrons in valence shell	1	2	3	4	5	6	7	8
Valence (Combining capacity)	1	2	3	4	5,3	6,2	7,1	8,0

In addition to that some elements have variable valence. For example, most of the elements of group 15 which have 5 valence electrons show two valences 3 and 5. Similarly transition metals and inner transition metals also show variable oxidation states.

#### Anomalous properties of second period elements:

As we know, the elements of the same group show similar physical and chemical properties. However, the first element of each group differs from other members of the group in certain properties. For example, lithium and beryllium form more covalent compounds, unlike the alkali and alkali earth metals which predominantly form ionic compounds. The elements of the second period have only four orbitals (2s & 2p) in the valence shell and have a maximum co-valence of 4, whereas the other members of the subsequent periods have more orbitals in their valence shell and shows higher valences. For example, boron forms  $\text{BF}_4^-$  and aluminium forms  $\text{AlF}_6^{3-}$ .

### Diagonal Relationship

On moving diagonally across the periodic table, the second and third period elements show certain similarities. Even though the similarity is not same as we see in a group, it is quite pronounced in the following pair of elements.

The similarity in properties existing between the diagonally placed elements is called 'diagonal relationship'.

### Periodic Trends and Chemical Reactivity:

The physical and chemical properties of elements depend on the valence shell electronic configuration as discussed earlier. The elements on the left side of the periodic table have less ionisation energy and readily lose their valence electrons. On the other hand, the elements on right side of the periodic table have high electron affinity and readily accept electrons. As a consequence of this, elements of these extreme ends show high reactivity when compared to the elements present in the middle. The noble gases having completely filled electronic configuration neither accept nor lose their electron readily and hence they are chemically inert in nature.

The ionisation energy is directly related to the metallic character and the elements located in the lower left portion of the periodic table have less ionisation energy and therefore show metallic character. On the other hand the elements located in the top right portion have very high ionisation energy and are non-metallic in nature.

Let us analyse the nature of the compounds formed by elements from both sides of the periodic table. Consider the reaction of alkali metals and halogens with oxygen to give the corresponding oxides.

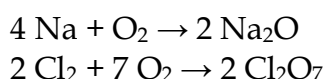

Since sodium oxide reacts with water to give strong base sodium hydroxide, it is a basic oxide. Conversely  $\text{Cl}_2\text{O}_7$  gives strong acid called perchloric acid upon reaction with water So, it is an acidic oxide.



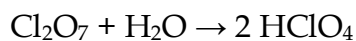

Thus, the elements from the two extreme ends of the periodic table behave differently as expected.

As we move down the group, the ionisation energy decreases and the electropositive character of elements increases. Hence, the hydroxides of these elements become more basic. For example, let us consider the nature of the second group hydroxides:

$\text{Be}(\text{OH})_2$  amphoteric;  $\text{Mg}(\text{OH})_2$  weakly basic;  $\text{Ba}(\text{OH})_2$  strongly basic Beryllium hydroxide reacts with both acid and base as it is amphoteric in nature.

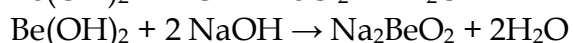
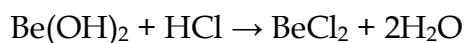

## Unit 9 - Solutions

### François - Marie

Raoult François - Marie Raoult was a French chemist who conducted research into the behaviour of solutions, especially their physical properties.

In his first research paper, he described the action of solutes in depressing the freezing point of the solutions. He also gave a relation between the vapour pressure of the solution with the molecular weight of the solute.

### INTRODUCTION

There are many chemicals that play an important role in our daily life. All these chemicals are in different physical forms, viz solid, liquid and gas. If we do close examination on their composition, we could find that most of them are mixtures and rarely pure substances. One more interesting aspect is that most of the mixtures are homogeneous irrespective of their physical state and such homogeneous mixtures are called as solutions.

Sea water is one of the naturally existing solutions which covers more than 70% of the earth's surface. We cannot imagine life on earth without sea water. It contains many dissolved solids, mostly NaCl. Another important naturally occurring solution is air. Air is a homogeneous mixture of nitrogen, oxygen, carbon dioxide, and other trace gases. Even solid material such as brass is a homogeneous mixture of copper and zinc.

In the above examples the solutions are in different physical states viz... liquid (sea water), gas (air) and solid (alloys), and one common property of all the above is their homogeneity. The homogeneity implies uniform distribution of their constituents or components throughout the mixture. In this chapter, we learn about the solutions and their properties.

#### Types of solutions

A solution is a homogeneous mixture of two or more substances, consisting of atoms, ions or molecules. The compound that is present in largest amount in a homogeneous mixture is called the solvent, and others are solutes. For example, when a small amount of NaCl is dissolved in water, a homogeneous solution is obtained. In this solution,  $\text{Na}^+$  and  $\text{Cl}^-$  ions are uniformly distributed in water. Here water is the solvent as the amount of water is more compared to the amount of NaCl present in this solution, and NaCl is the solute.

The commonly used solutions are the solutions in which a solid solute is dissolved in a liquid solvent. However, solute or solvent can be in any of the three states of matter (solid, liquid, gas). If water is used as the solvent, the resultant solution is called as an aqueous solution. If solvents (Benzene,  $\text{CCl}_4$ , ether etc.) other than water is used, then the resultant solution is called as a non-aqueous solution.

The following table illustrates the different types of solutions based on the physical state of the solute and solvent.

### Types and examples of solutions

S.No.	State of solution	Solute	Solvent	Examples
1	Gaseous solution	Gas	Gas	Air (A mixture of nitrogen, oxygen and other gases)
		Liquid	Gas	Humid oxygen (Oxygen containing water)
		Solid	Gas	Camphor in nitrogen gas
2	Liquid solutions	Gas	Liquid	CO <sub>2</sub> dissolved in water (carbonated water)
		Liquid	Liquid	Ethanol dissolved in water
		Solid	Liquid	Salt water
3	Solid solutions	Gas	Solid	Solution of H <sub>2</sub> in palladium
		Liquid	Solid	Amalgam of potassium (used for dental filling)
		Solid	Solid	Gold alloy (of copper used in making Jewellery)

### Expressing concentration of solutions

In our life we have come across many solutions of varying strengths or concentrations such as mouthwash, antiseptic solutions, household disinfectants etc... Have you ever noticed the concentration of the ingredients present in those solutions? For example, chlorhexidine mouthwash solution contains 0.2 % (w/v) chlorhexidine gluconate; The concentration of the commercially available hydrogen peroxide is 3% (w/v). Similarly, other terms such as ppm (TDS of water), molar and normal (laboratory reagents) are used to express the concentration of the solution. The concentration of a solution gives the amount of solute present in a given quantity of solvent. As we have seen, there are different ways of expressing the concentration of a solution. Let us learn the different concentration terms and to prepare a solution of a specific concentration.

### Different concentration units and their illustrations

Concentration term	Expression	Illustration
Molality (m)	$\frac{\text{Number of moles of solute}}{\text{Mass of the solvent (in kg)}}$	<p>The molality of the solution containing 45g of Glucose dissolved in 2kg of water</p> $\frac{\text{Number of moles of solute}}{\text{Mass of the solvent (in kg)}} = \frac{\left(\frac{45}{180}\right)}{2}$ $= \frac{0.25}{2} = 0.125m$
Molarity (M)	$\frac{\text{Number of moles of solute}}{\text{Volume of solution (in L)}}$	<p>5.845 g of sodium chloride is dissolved in water and the solution was made up to 500 mL using a standard flask. The strength of the solution in molarity is</p> $\frac{\text{Number of moles of solute}}{\text{Volume of solution (in L)}} = \frac{\left(\frac{5.845}{58.45}\right)}{0.5}$ $= \frac{0.1}{0.5} = 0.2M$
Normality (N)	$\frac{\text{Number of gram equivalents of solute}}{\text{Volume of solution (in L)}}$	<p>3.15 g of oxalic acid 32hydrate, is dissolved in water and the solution was made up to 100 mL using a standard flask. The strength of the solution in normality is</p> $= \frac{\text{Number of gram equivalents of solute}}{\text{Volume of solution (in L)}}$ $= \frac{\left(\frac{\text{mass of oxalic acid}}{\text{Equivalent mass of oxalic acid}}\right)}{\text{volume of solution (in L)}} = \frac{\left(\frac{3.15}{63}\right)}{0.1}$ $= \frac{0.05}{0.1} = 0.5N$



Formality (F)

5.85g of sodium chloride is dissolved in water and the solution was made up to 500 mL using a standard flask. The strength of the solution in formality is

$$\frac{\text{Number of Formula mass of solute}}{\text{Volume of solution (in L)}}$$

$$\text{formality} = \frac{\text{Number of Formula mass of solute}}{\text{Volume of solution (in L)}}$$

$$= \frac{5.85}{58.5 \times 0.5L}$$

$$= 0.2F$$

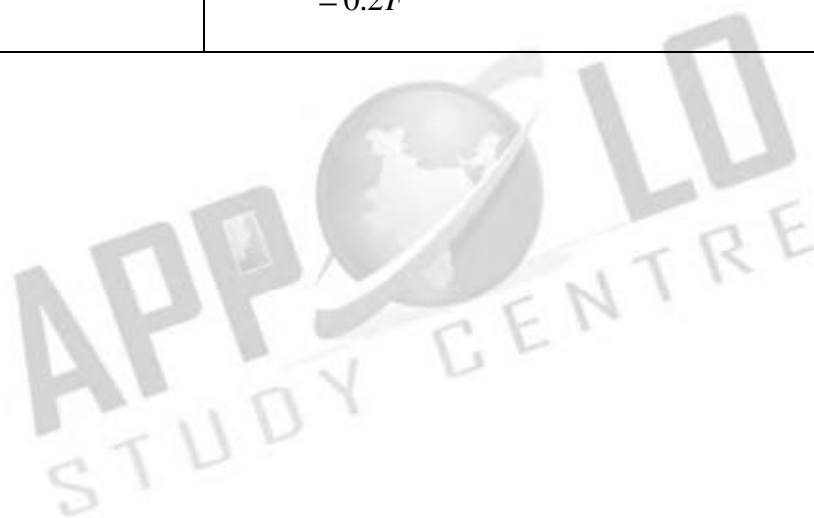

$$= \frac{\text{Number of moles of the component}}{\text{Total number of moles of all the components present in solution}}$$

Consider a solution of the containing two components A and B whose mole fractions are  $x_A$  and  $x_B$ , respectively. Let the number of moles of the two components A and B be  $n_A$  and  $n_B$ , respectively.

$$x_A = \frac{n_A}{n_A + n_B} \text{ and } x_B = \frac{n_B}{n_A + n_B}$$

Now,

$$x_A + x_B = \frac{n_A}{n_A + n_B} + \frac{n_B}{n_A + n_B} = 1$$

0.5 mole of ethanol is mixed with 1.5 of water.

The mole fraction of ethanol in the above solution is

$$= \frac{\text{Number of moles of the ethanol}}{\text{Total number of moles of ethanol and water}}$$

$$= \frac{0.5}{1.5 + 0.5} = \frac{0.5}{2.0} = 0.25$$

The mole fraction of water in the above solution is

$$= \frac{\text{Number of moles of water}}{\text{Total number of moles of ethanol and water}}$$

$$= \frac{1.5}{2.0} = 0.75$$

The mole fraction of water can also be calculated as follows  
mole fraction of water + mole fraction of ethanol = 1; mole fraction of water = 1 - mole fraction of ethanol = 1 - 0.25 = 0.75

$$\frac{\text{mass of the solute (in g)}}{\text{mass of solution (in g)}} \times 100$$

Neomycin, aminoglycoside antibiotic cream contains 300 mg of neomycin sulphate the active ingredient, in 30g of ointment base. The mass percentage of neomycin is

$$= \frac{\text{Number of the neomycin sulphate (in g)}}{\text{mass of solution (in g)}} \times 100$$

$$= \frac{0.3g}{30g} \times 100 = 1\% w/w$$

Volume	$\frac{\text{Volume of the solute (in g)}}{\text{Volume of solution (in g)}} \times 100$	<p>50 mL of tincture of benzoin, an antiseptic solution contains 10 mL of benzoin. The volume percentage of benzoin</p> $= \frac{\text{Volume of the benzoin (in g)}}{\text{Volume of solution (in g)}} \times 100$ $= \frac{10}{50} \times 100 = 20\% \text{ v/v}$
Mass by volume percentage (w/v)	$\frac{\text{Mass of the solute (in g)}}{\text{Volume of solution (in g)}} \times 100$	<p>A 60 mL of paracetamol paediatric oral suspension contains 3g of paracetamol. The mass percentage of paracetamol is</p> $\frac{\text{Mass of the paracetamol (in g)}}{\text{Volume of solution (in g)}} \times 100 =$ $= \frac{3}{60} \times 100 = 5\% \text{ w/v}$
Parts per million (ppm)	$= \frac{\text{Mass of the solute}}{\text{mass of solution}} \times 10^6$	<p>50g of tap water contains 20 mg of dissolved solids. The TDS value in ppm is</p> $\frac{\text{Mass of the dissolved solids}}{\text{mass of the water}} \times 10^6$ $\frac{20 \times 10^{-3} \text{ g}}{50 \text{ g}} \times 10^6 = 400 \text{ ppm}$

The concentration of a solution is expressed in different units. The choice of unit depends on the type of measurement applied. For example, in complexometric titrations involving EDTA, the reaction between EDTA and the metal ions takes place in the 1:1 mole ratio and hence molar solutions are used in this titrations. In the redox and neutralisation titrations we use normal solutions. The mole fraction is used to calculate the partial pressure of gases and the vapour pressure of solutions. The percentage units are used to express the active

ingredients present in therapeutics, and the ppm is used to express the quantity of solutes present in small amounts in solutions.

### Standard solutions and working standards

A standard solution or a stock solution is a solution whose concentration is accurately known. A standard solution of required concentration can be prepared by dissolving a required amount of a solute, in a suitable amount of solvent. Its done by (i) transforming a known amount of a solute to a standard flask of definite volume. (ii) a small amount of water is added to the flask and shaken well to dissolve the solute. (iii) then water is added to the flask to bring the solution level to the mark indicated at the top end of the flask. (iv) the flask is stoppered and shaken well to make concentration uniform.

At the time of experiment, the solution with required concentration is prepared by diluting the stock solution. This diluted solution is usually called working standard. A known volume of stock solution is transferred to a new container and brought to the calculated volume. The necessary volumes of the stock solution and final volume can be calculated using the following expression.

$$C_s V_s = C_w V_w$$

Where the  $C_s$  &  $V_s$  are concentration and volume of the stock solution and  $C_w$  &  $V_w$  are concentration and volume of the working standard, respectively.

#### Advantages of using standard solutions:

1. The error in weighing the solute can be minimised by using concentrated stock solution that requires large quantity of solute.
2. We can prepare working standards of different concentrations by diluting the stock solution, which is more efficient since consistency is maintained.
3. Some of the concentrated solutions are more stable and are less likely to support microbial growth than working standards used in the experiments.

#### Example Problem

1. What volume of 4M HCl and 2M HCl should be mixed to get 500 mL of 2.5 M HCl?

Let the volume of 4M HCl required to prepare 500 mL of 2.5

MHCl = x mL

Therefore, the required volume of 2M HCl = (500 - x) mL

$$C_1 V_1 + C_2 V_2 = C_3 V_3$$

$$(4x) + 2(500 - x) = 2.5 \times 500$$

$$\begin{aligned}
 4x+1000-2x &= 1250 \\
 2x &= 1250 - 1000 \\
 x &= 250/2 \\
 &= 125 \text{ mL}
 \end{aligned}$$

Hence, volume of 4M HCl required = 125 mL Volume of 2M HCl required = (500 - 125) mL= 375 mL

### Solubility of the solutes

Solubility of a solute is the maximum amount of solute that can be dissolved in a specific amount of solvent at a specified temperature. When maximum amount of solute is dissolved in a solvent, any more addition of solute will result in precipitation at a given temperature and pressure. Such a solution is called as a saturated solution. The solubility of a substance at a given temperature is defined as the amount of the solute that can be dissolved in 100 g of the solvent at a given temperature to form a saturated solution.

#### Factors influencing the solubility

The solubility of a solute generally depends on the nature of the solute and the solvent in which it is dissolved. It also depends on the temperature and pressure of the solution.

#### Nature of solute and solvent:

Sodium chloride, an ionic compound, dissolves readily in a polar solvent such as water, but it does not dissolve in non-polar organic solvents such as benzene or toluene. Many organic compounds dissolve readily in organic solvents and do not dissolve in water. Different gases dissolve in water to different extents: for example, ammonia is more soluble than oxygen in water.

#### Effect of temperature:

#### Solid solute in liquid solvent:

Generally, the solubility of a solid solute in a liquid solvent increases with increase in temperature. When the temperature is increased, the average kinetic energy of the molecules of the solute and the solvent increases. The increase in kinetic energy facilitates the solvent molecules to break the intermolecular attractive forces that keep the solute molecules together and hence the solubility increases.

When a solid is added to a solvent, it begins to dissolve. i.e. the solute leaves from the solid state (dissolution). After some time, some of the dissolved solute returns back to the

solid state (recrystallisation). If there is excess of solid present, the rate of both these processes becomes equal at a particular stage. At this stage an equilibrium is established between the solid solute molecules and dissolved solute molecules.



According to Le-Chatelier principle, if the dissolution process is endothermic, the increase in temperature will shift the equilibrium towards right i.e solubility increases for an exothermic reaction, the increase in temperature decreases the solubility. The solubilities of ammonium nitrate, calcium chloride, ceric sulphate nano-hydrate and sodium chloride in water at different temperatures are given in the following graph.

### Plot of solubility versus temperature for selective compounds

The following conclusions are drawn from the above graph.

The solubility of sodium chloride does not vary appreciable as the maximum solubility is achieved at normal temperature. In fact, there is only 10 % increase in solubility between 0 ° to 100 °C.

The dissolution process of ammonium nitrate is endothermic, the solubility increases steeply with increase in temperature.

In the case of ceric sulphate, the dissolution is exothermic and the solubility decreases with increase in temperature.

Even though the dissolution of calcium chloride is exothermic, the solubility increases moderately with increase in temperature. Here, the entropy factor also plays a significant role in deciding the position of the equilibrium.

### Gaseous solute in liquid solvent:

In the case of gaseous solute in liquid solvent, the solubility decreases with increase in temperature. When a gaseous solute dissolves in a liquid solvent, its molecules interact with solvent molecules with weak intermolecular forces. When the temperature increases, the average kinetic energy of the molecules present in the solution also increases. The increase in kinetic energy breaks the weak intermolecular forces between the gaseous solute and liquid solvent which results in the release of the dissolved gas molecules to the gaseous state. Moreover, the dissolution of most of the gases in liquid solvents is an exothermic process, and in such processes, the increase in temperature decreases the dissolution of gaseous molecules.

### Activity:

Open the soda bottle and put a balloon over it. The balloon will inflate with the released carbon dioxide from the soda. Carry out the same experiment by placing the soda bottle in a container of hot water. You will observe the balloon is inflated much faster now. This shows the decrease in solubility of gases in solution with increase in temperature. In the

rivers where hot water is discharged from industrial plants, the aquatic lives are less sustained due to the decreased availability of dissolved oxygen.

### When pressure is increased

#### Effect of pressure:

Generally the change in pressure does not have any significant effect in the solubility of solids and liquids as they are not compressible. However, the solubility of gases generally increases with increase of pressure.

Consider a saturated solution of a gaseous solute dissolved in a liquid solvent in a closed container. In such a system, the following equilibrium exists.

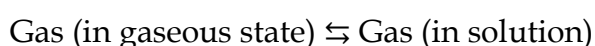

According to Le-Chatelier principle, the increase in pressure will shift the equilibrium in the direction which will reduce the pressure. Therefore, more number of gaseous molecules dissolves in the solvent and the solubility increases.

#### Henry's law

William Henry investigated the relationship between pressure and solubility of a gaseous solute in a particular solvent. According to him, "the partial pressure of the gas in vapour phase (vapour pressure of the solute) is directly proportional to the mole fraction(x) of the gaseous solute in the solution at low concentrations". This statement is known as Henry's law.

Henry's law can be expressed as,

$$P_{\text{solute}} \propto X_{\text{solute in solution}}$$

$$P_{\text{solute}} = K_H X_{\text{solute in solution}}$$

Here,  $P_{\text{solute}}$  represents the partial pressure of the gas in vapour state which is commonly called as vapour pressure.  $X_{\text{solute in solution}}$  represents the mole fraction of solute in the solution.  $K_H$  is an empirical constant with the dimensions of pressure. The value of ' $K_H$ ' depends on the nature of the gaseous solute and solvent. The above equation is a straight-line in the form of  $y=mx$ . The plot partial pressure of the gas against its mole fraction in a solution will give a straight line as shown. The slope of the straight line gives the value of  $K_H$ .

### Solubility of HCl gas in cyclohexane at 293 K

#### Limitations of Henry's law

- Henry's law is applicable at moderate temperature and pressure only.
- Only the less soluble gases obey Henry's law
- The gases reacting with the solvent do not obey Henry's law. For example, ammonia or HCl reacts with water and hence does not obey this law.



- The gases obeying Henry's law should not associate or dissociate while dissolving in the solvent.

Example Problem 2:

0.24 g of a gas dissolves in 1 L of water at 1.5 atm pressure. Calculate the amount of dissolved gas when the pressure is raised to 6.0 atm at constant temperature.

$$P_{\text{solute}} = K_H X_{\text{solute in solution}}$$

At pressure 1.5 atm,

$$P_1 = K_H X_1 \quad (1)$$

At pressure 6.0 atm,

$$P_2 = K_H X_2 \quad (2)$$

Dividing equation (1) by (2)

From equation  $p_1 / p_2 = x_1 / x_2$

$$1.5/6.0 = 0.24/x_2$$

Therefore  $X_2 = 0.24 \times 6.0/1.5 = 0.96 \text{ g/L}$

### Vapour pressure of liquid

Generally, liquids have a tendency to evaporate. If the kinetic energy of molecules in the liquid state overcomes the intermolecular force of attraction between them, then the molecules will escape from the liquid state. This process is called 'evaporation' and it happens on the surface of the liquid.

If evaporation is carried out in a closed container then the vapour remains in contact with the surface of the liquid. These vapour molecules are in continuous random motion during which they collide with each other and also with the walls of the container. As the collision is inelastic, they lose their energy and as a result the vapour returns back to liquid state. This process is called as 'condensation'.



Evaporation and condensation are continuous processes. If the process is carried out in a closed system, a stage is reached when the rate of evaporation becomes equal to the rate of condensation. Thus, an equilibrium is established between liquid and its vapour. The pressure of the vapour in equilibrium with its liquid is called vapour pressure of the liquid at the given temperature. The vapour pressure of a liquid depends on its nature, temperature and the surface area. The following simple apparatus demonstrates the measurement of vapour pressure of a liquid.

**a) A closed round bottomed flask in which ethanol is in equilibrium with its vapour. b) In the same setup the vapour is allowed to escape through a U tube filled with mercury. The escaped vapour pushes the mercury in the U tube and the difference in mercury level gives the vapour pressure of ethanol present in the RB flask.**

### Vapour pressure of liquid solutions

When a solute (of any physical state - solid, liquid or gas ) is dissolved in a liquid solvent the resultant solution is called a liquid solution. The solution which contains only two components (one solvent and one solute) is called a binary solution. We have already discussed the solution of a gaseous solute in liquid solvent under Henry's law.

### Vapour pressure of binary solution of liquid in liquids

Now, let us consider a binary liquid solution formed by dissolving a liquid solute 'A' in a pure solvent 'B' in a closed vessel. Both the components A and B present in the solution would evaporate and an equilibrium will be established between the liquid and vapour phases of the components A and B.

The French chemist Raoult, proposed a quantitative relationship between the partial pressures and the mole fractions of two components A & B, which is known as Raoult's Law. This law states that "in the case of a solution of volatile liquids, the partial vapour pressure of each component (A & B) of the solution is directly proportional to its mole fraction".

**According to Raoult's law,**

$$P_A \propto X_A \quad (9.3)$$

$$P_A = k X_A$$

When  $X_A = 1$ ,  $k = P_A^\circ$

Where  $P_A^\circ$  is the vapour pressure of pure component 'A' at the same temperature.

**Therefore,**

$$P_A = P_A^\circ X_A \quad (9.4)$$

Similarly, for component 'B'

$$P_B = P_B^\circ X_B \quad (9.5)$$

$X_A$  and  $X_B$  are the mole fraction of the components A and B respectively.

According to Dalton's law of partial pressure the total pressure in a closed vessel will be equal to the sum of the partial pressures of the individual components.

Hence,

$$P_{total} = P_A + P_B \quad (9.6)$$

Substituting the values of  $p_A$  and  $p_B$  from equations (9.4) and (9.5) in the above equation,

$$P_{total} = X_A P_A^\circ + X_B P_B^\circ \quad (9.7)$$

We know that  $X_A + X_B = 1$  or  $X_A = 1 - X_B$

Therefore,

$$P_{total} = (1 - X_B) P_A^\circ + X_B P_B^\circ \quad (9.8)$$

$$P_{total} = P_A^\circ + X_B (P_B^\circ - P_A^\circ) \quad (9.9)$$

The above equation is of the straight-line equation form  $y = mx + c$ . The plot of  $P_{total}$  versus  $X_B$  will give a straight line with  $(P_B^\circ - P_A^\circ)$  as slope and  $P_A^\circ$  as the y intercept.

Let us consider the liquid solution containing toluene (solute) in benzene (solvent).

The variation of vapour pressure of pure benzene and toluene with its mole fraction is given in the graph.

### Solution of benzene in toluene obeying Raoult's law

The vapour pressures of pure toluene and pure benzene are 22.3 and 74.7 mmHg, respectively. The above graph shows, the partial vapour pressure of the pure components increases linearly with the increase in the mole fraction of the respective components. The

total pressure at any composition of the solute and solvent is given by the following straight line (represented as red line) equation.

$$P_{\text{solution}} = P_{\text{toluene}}^{\circ} + X_{\text{benzene}} (P_{\text{benzene}}^{\circ} - P_{\text{toluene}}^{\circ}) \quad (9.10)$$

### Vapour pressure of binary solution of solids in liquids

When a nonvolatile solute is dissolved in a pure solvent, the vapour pressure of the pure solvent will decrease. In such solutions, the vapour pressure of the solution will depend only on the solvent molecules as the solute is nonvolatile.

For example, when sodium chloride is added to the water, the vapour pressure of the salt solution is lowered. The vapour pressure of the solution is determined by the number of molecules of the solvent present in the surface at any time and is proportional to the mole fraction of the solvent.

#### Rate of vapourization reduced by presence of nonvolatile solute

$$P_{\text{solution}} = a X_A \quad (9.11)$$

Where  $X_A$  is the mole fraction of the solvent

$$P_{\text{solution}} = k X_A \quad (9.11)$$

When  $X_A = 1$ ,  $K = P_{\text{solvent}}^{\circ}$

( $P_{\text{solvent}}^{\circ}$  is the partial pressure of pure solvent)

$$P_{\text{solution}} = P_{\text{solvent}}^{\circ} X_A \quad (9.13)$$

$$\frac{P_{\text{solution}}}{P_{\text{solvent}}^{\circ}} = X_A \quad (9.14)$$

$$1 - \frac{P_{\text{solution}}}{P_{\text{solvent}}^{\circ}} = 1 - X_A \quad (9.15)$$

$$\frac{P_{\text{solvent}}^{\circ} - P_{\text{solution}}}{P_{\text{solvent}}^{\circ}} = X_B \quad (9.16)$$

Where  $X_B$  is the mole fraction of the solute ( $\because X_A + X_B = 1, X_B = 1 - X_A$ )

The above expression gives the relative lowering of vapour pressure. Based on this expression, Raoult's Law can also be stated as "the relative lowering of vapour pressure of an ideal solution containing the nonvolatile solute is equal to the mole fraction of the solute at a given temperature".

### Comparison of Raoult's law and Henry's law

According to Raoult's law, for a solution containing a nonvolatile solute

$$P_{\text{solution}} = P_{\text{solvent}}^{\circ} X_{\text{solute}} \quad (9.17)$$

According to Henry's law:

$$P_{\text{solute}} = K_H X_{\text{solute in solution}} \quad (9.18)$$

The difference between the above two expressions is the proportionality constant  $P_A^{\circ}$  (Raoult's Law) and  $K_H$  (Henry's Law). Henry's law is applicable to solution containing gaseous solute in liquid solvent, while the Raoult's Law is applicable to nonvolatile solid solute in a liquid solvent. If the solute is non volatile then the Henry's law constant will become equal to the vapour pressure of the pure solvent

( $P_A^{\circ}$ ) and thus, Raoult's law becomes a special case of Henry's law. For very dilute solutions the solvent obeys Raoult's law and the solute obeys Henry's law. **Ideal and non-ideal solutions**

### Ideal Solutions:

An ideal solution is a solution in which each component i.e. the solute as well as the solvent obeys the Raoult's law over the entire range of concentration. Practically no solution is ideal over the entire range of concentration. However, when the concentration of solute is very low, the dilute solution behaves ideally. If the two components present in the solution (A and B) are identical in size, structure, and having almost similar intermolecular attractive forces between them (i.e. between A-A, B-B and B-A) and then the solution tends to behave like an ideal solution.

For an ideal solution

1. There is no change in the volume on mixing the two components (solute & solvents). ( $\Delta V_{\text{mixing}} = 0$ )
2. There is no exchange of heat when the solute is dissolved in solvent ( $\Delta H_{\text{mixing}} = 0$ ).

3. Escaping tendency of the solute and the solvent present in it should be same as in pure liquids.

**Examples for ideal solutions:** (Benzene & Toluene) ; (n-hexane & n-heptane) ; (Ethyl bromide & Ethyl iodide) ; (Chlorobenzene&Bromobenzene).

### Non-ideal solutions

The solutions which do not obey Raoult's law over the entire range of concentration, are called non-ideal solutions. For a non-ideal solution, there is a change in the volume and enthalpy upon mixing.

i.e.  $\Delta H_{\text{mixing}} \neq 0$  &  $\Delta V_{\text{mixing}} \neq 0$ . The deviation of the non-ideal solutions from the Raoult's law can either be positive or negative.

### Non-ideal solutions - positive deviation from Raoult's Law:

The nature of the deviation from the Raoult's law can be explained in terms of the intermolecular interactions between solute (B) and solvent (A). Consider a case in which the intermolecular attractive forces between A and B are weaker than those between the molecules of

A (A-A) and molecules of B (B - B). The molecules present in such a solution have a greater tendency to escape from the solution when compared to the ideal solution formed by A and B, in which the intermolecular attractive forces (A-A, B-B, A-B) are almost similar. Consequently, the vapour pressure of such non-ideal solution increases and it is greater than the sum of the vapour pressure of A and B as predicted by the Raoult's law. This type of deviation is called positive deviation.

Here,  $P_A > P_A^\circ X_A$  and  $P_B > P_B^\circ X_B$

Hence  $P_{\text{total}} > P_A^\circ X_A + P_B^\circ X_B$  (9.19)

Let us understand the positive deviation by considering a solution of ethyl alcohol and water. In this solution the hydrogen bonding interaction between ethanol and water is weaker than those hydrogen bonding interactions amongst themselves (ethyl alcohol-ethyl alcohol and water-water interactions). This results in the increased evaporation of both components ( $\text{H}_2\text{O}$  and  $\text{C}_2\text{H}_5\text{OH}$ ) from the aqueous solution of ethanol. Consequently, the vapour pressure of the solution is greater than the vapour pressure predicted by Raoult's law. Here, the mixing process is endothermic i.e.  $\Delta H_{\text{mixing}} > 0$  and there will be a slight increase in volume ( $\Delta V_{\text{mixing}} > 0$ ).

**Examples for non-ideal solutions showing positive deviations:** Ethyl alcohol & cyclohexane, Benzene & acetone, Carbon tetrachloride & chloroform, Acetone & ethyl alcohol, Ethyl alcohol & water.

**Positive deviations from Raoult's law. The dotted line (-----) is ideal behavior and the solid lines (\_\_\_\_) is actual behaviour**

### **Non-ideal solutions - negative deviation from Raoult's Law:**

Let us consider a case where the attractive forces between solute (A) and solvent (B) are stronger than the intermolecular attractive forces between the individual components (A-A & B-B). Here, the escaping tendency of A and B will be lower when compared with an ideal solution formed by A and B. Hence, the vapour pressure of such solutions will be lower than the sum of the vapour pressure of A and B. This type of deviation is called negative deviation. For the negative deviation  $P_A < P_A^\circ X_A$  and  $P_B < P_B^\circ X_B$ .

Let us consider a solution of phenol and aniline. Both phenol and aniline form hydrogen bonding interactions amongst themselves. However, when mixed with aniline, the phenol molecule forms hydrogen bonding interactions with aniline, which are stronger than the hydrogen bonds formed amongst themselves. Formation of new hydrogen bonds considerably reduce the escaping tendency of phenol and aniline from the solution. As a result, the vapour pressure of the solution is less and there is a slight decrease in volume ( $\Delta V_{\text{mixing}} < 0$ ) on mixing. During this process evolution of heat takes place i.e.  $\Delta H_{\text{mixing}} < 0$  (exothermic)

**Examples for non-ideal solutions showing negative deviation:** Acetone + chloroform, Chloroform + diethyl ether, Acetone + aniline, Chloroform + Benzene.

**Negative deviation from Raoult's law. The dotted line (-----) is ideal behavior and the solid lines (\_\_\_\_) is actual behaviour**

### **Factors responsible for deviation from Raoult's law**

The deviation of solution from ideal behavior is attributed to the following factors.

#### **i) Solute-solvent interactions**

For an ideal solution, the interaction between the solvent molecules (A-A), the solute molecules (B-B) and between the solvent & solute molecules (A-B) are expected to be similar. If these interactions are dissimilar, then there will be a deviation from ideal behavior.

#### **ii) Dissociation of solute**

When a solute present in a solution dissociates to give its constituent ions, the resultant ions interact strongly with the solvent and cause deviation from Raoult's law.

For example, a solution of potassium chloride in water deviates from ideal behavior because the solute dissociates to give  $K^+$  and  $Cl^-$  ion which form strong ion-dipole interaction with water molecules.

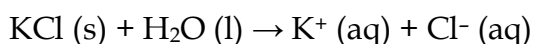

### iii) Association of solute

Association of solute molecules can also cause deviation from ideal behaviour. For example, in solution, acetic acid exists as a dimer by forming intermolecular hydrogen bonds, and hence deviates from Raoult's law.

#### Acetic acid (dimer)

### iv) Temperature

An increase in temperature of the solution increases the average kinetic energy of the molecules present in the solution which causes decrease in the attractive force between them. As a result, the solution deviates from ideal behaviour.

### v) Pressure

At high pressure the molecules tend to stay close to each other and therefore there will be an increase in their intermolecular attraction. Thus, a solution deviates from Raoult's law at high pressure.

### vi) Concentration

If a solution is sufficiently dilute there is no pronounced solvent-solute interaction because the number of solute molecules are very low compared to the solvent. When the concentration is increased by adding solute, the solvent-solute interaction becomes significant. This causes deviation from the Raoult's law.

## Colligative properties

Pure water is tasteless. When you add sugar it becomes sweet, while addition of salt makes it salty. It implies that the properties of a solution depend on the nature of solute particles present in the solution. However, for an ideal dilute solution, the properties, namely, relative lowering of vapour pressure, elevation of boiling point, depression in freezing point and osmotic pressure do not depend on the chemical nature of the solute but depends only on the number of solute particles (ions/molecules) present in the solution. These four properties are known as colligative properties. Though the magnitude of these properties are small, they have plenty of practical applications. For example the osmotic pressure is important for some vital biological systems.

### Relative lowering of vapour pressure

The vapour pressure of a solution containing a nonvolatile, non-electrolyte solute is always lower than the vapour pressure of the pure solvent. Consider a closed system in which a pure solvent is in equilibrium with its vapour. At equilibrium the molar Gibbs free

energies of solvent in the liquid and gaseous phase are equal ( $\Delta G = 0$ ). When a solute is added to this solvent, the dissolution takes place and its free energy ( $G$ ) decreases due to increase in entropy. In order to maintain the equilibrium, the free energy of the vapour phase must also decrease. At a given temperature, the only way to lower the free energy of the vapour is to reduce its pressure. Thus the vapour pressure of the solution must decrease to maintain the equilibrium.

We know that from the Raoult's law the relative lowering of the vapour pressure is equal to the mole fraction of the solute (equation 9.16)

### Measuring relative lowering of vapour pressure

From the above equation, it is clear that the relative lowering of vapour pressure depends only on the mole fraction of the solute ( $X_B$ ) and is independent of its nature. Therefore, relative lowering of vapour pressure is a colligative property.

### Determination of molar mass from relative lowering of vapour pressure

The measurement of relative lowering of vapour pressure can be used to determine the molar mass of a nonvolatile solute. In this method, a known mass of the solute is dissolved in a known quantity of solvent. The relative lowering of vapour pressure is measured experimentally.

According to Raoult's law the relative lowering of vapor pressure is,

$$\frac{P_{solvent}^{\circ} - P_{solution}}{P_{solvent}^{\circ}} = X_B \quad (9.20)$$

Let  $W_A$  and  $W_B$  be the weights of the solvent and solute respectively and their corresponding molar masses are  $M_A$  and  $M_B$ , then the mole fraction of the solute  $X_B$  is

$$X_B = \frac{n_B}{n_A + n_B} \quad (9.21)$$

Here,  $n_A$  &  $n_B$  are the moles of the solvent and the solute respectively. For dilute solutions  $n_A \gg n_B$ . Hence  $n_A + n_B \approx n_A$ . Now

$$X_B = \frac{n_B}{n_A}$$

Number of moles of solvent and the solute are,



$$n_A = \frac{W_A}{M_A}, n_B = \frac{W_B}{M_B}$$

Therefore,

$$X_B = \frac{\frac{W_B}{M_B}}{\frac{W_A}{M_A}} \quad (9.22)$$

From the equation (9.22) the molar mass of the solute ( $M_B$ ) can be calculated using the known values of  $w_A$ ,  $w_B$ ,  $M_A$  and the measured relative lowering of vapour pressure.

### Example Problem3:

An aqueous solution of 2 % nonvolatile solute exerts a pressure of 1.004bar at the boiling point of the solvent. What is the molar mass of the solute when  $P_A^\circ$  is 1.013 bar?

$$\frac{\Delta P}{P_A^\circ} = \frac{W_a \times M_A}{M_a \times W_A}$$

In a 2 % solution weight of the solute is 2 g and solvent is 98 g

$$\frac{\Delta P}{\text{bar}} = P_A^\circ - P_{\text{solution}} = 1.013 - 1.004 \text{ bar} = 0.009$$

$$M_B = \frac{P_A^\circ \times W_B \times M_A}{\Delta P \times W_A}$$

$$M_B = 2 \times 18 \times 1.013 / (98 \times 0.009)$$

$$= 41.3 \text{ g mol}^{-1}$$

### Evaluate Yourself Elevation of boiling point

Boiling point is an important physical property of a liquid. The boiling point of a liquid is the temperature at which its vapour pressure becomes equal to the atmospheric pressure (1 atm). When a nonvolatile solute is added to a pure solvent at its boiling point, the vapour pressure of the solution is lowered below 1 atm. To bring the vapour pressure again to 1 atm, the temperature of the solution has to be increased. As a result, the solution boils at a higher temperature ( $T_b$ ) than the boiling point of the pure solvent ( $T_b^\circ$ ). This increase in the boiling point is known as elevation of boiling point. A plot of vapour pressure versus temperature for water and an aqueous solution is given below

Figure 9.11 Elevation of boiling point and depression in freezing point

The vapour pressure of the solution increases with increase in temperature as shown in the above figure. The variation of vapour pressure with respect to temperature for pure water is given by the violet coloured curve. At 100 °C the vapour pressure of water is equal to 1 atm. Hence the boiling point of water is 100 °C ( $T_b^\circ$ ). When a solute is added to water, the vapour pressure of the resultant solution is lowered. The variation of vapour pressure with respect to temperature for the solution is given by green curve. From the graph, it is evident the vapour pressure of the solution is equal to 1atm pressure at the temperature  $T_b$  which is greater than  $T_b^\circ$ . The difference between these two temperatures ( $T_b - T_b^\circ$ ) gives the elevation of boiling point.

The elevation of boiling point ( $\Delta T_b$ ) =  $T_b - T_b^\circ$

The elevation of boiling point is directly proportional to the concentration of the solute particles.

$$\Delta T_b \propto m \text{ ----- (9.23)}$$

$m$  is the concentration of solution expressed in molality.

$$\Delta T_b = K_b m \text{ ----- (9.24)}$$

Where  $K_b$  = molalboiling point elevation constant or Ebullioscopic constant.

If  $m=1$ , then  $\Delta T_b = K_b$ ;

Hence,  $K_b$  is equal to the elevation in boiling point for 1molal solution.  $K_b$  is calculated by the following expression

$$K_b = \frac{RT^2 M_{\text{solvent}}}{\Delta H_{\text{vapourisation}}}$$

### Determination of molar mass of solute from elevation of boiling point

If the solution is prepared by dissolving  $W_B$  g of solute in  $W_A$  g of solvent, then the molality is,

$$m = \frac{\text{Number of moles of solute} \times 100}{\text{Weight of solvent in grams}} \text{ .....(9.25)}$$

$$\text{Number of moles of solute} = \frac{W_B}{M_B} \text{ .....(9.26)}$$

Where,  $M_B$  = molar mass of the solute Therefore,

$$m = \frac{w_B \times 1000}{M_B \times w_A} \dots\dots\dots(9.27)$$

And

$$\Delta T_b = \frac{K_b \times w_B \times 1000}{M_B \times w_A} \dots\dots\dots(9.28)$$

Molar mass can be calculated by using (9.28)

$$M_B = \frac{K_b \times w_B \times 1000}{\Delta T_b \times w_A} \dots\dots\dots(9.29)$$

**Table 9.3 Molal boiling point elevation constant 'K<sub>b</sub>' for some solvents**

S. No.	Solvent	T <sub>b</sub> <sup>o</sup> (K)	K <sub>b</sub> (K kg mol <sup>-1</sup> )
1.	Water	373.15	0.52
2.	Ethanol	351.5	1.20
3.	Benzene	353.3	2.53
4.	Chloroform	334.4	3.63
5.	Ether	307.8	2.02
6.	Carbon tetrachloride	350.0	5.03
7.	Carbon disulphide	319.4	2.43
8.	Acetic acid	391.1	2.93
9.	Cyclohexane	353.74	2.79

**Example Problem 4**

0.75 g of an unknown substance is dissolved in 200 g solvent. If the elevation of boiling point is 0.15 K and molal elevation constant is 7.5 K Kg mol<sup>-1</sup> then, calculate the molar mass of unknown substance

$$\begin{aligned} \Delta T_b &= K_b m \\ &= K_b \times W_2 \times 1000 / M_2 \times W_1 \\ M_2 &= K_b \times W_2 \times 1000 / \Delta T_b \times W_1 \\ &= 7.5 \times 0.75 \times 1000 / 0.15 \times 200 \\ &= 187.5 \text{ g mol}^{-1} \end{aligned}$$

### Depression in freezing point

Freezing point of a substance is another important physical property like boiling point. Freezing point is defined as “the temperature at which the solid and the liquid states of the substance have the same vapour pressure”. At freezing point, the solid and liquid phases of the substance are in equilibrium. For example, the freezing point of water is 0 °C. At this temperature the ice and water are in equilibrium. When a non- volatile solute is added to water at its freezing point, the freezing point of the solution is lowered from 0 °C. The lowering of the freezing point of the solvent when a solute is added is called depression in freezing point ( $\Delta T_f$ ).

From the above graph, we infer that the freezing point ( $T_f^o$ ) is 0 °C as the vapour pressure at this temperature is 1atm (atmospheric pressure). The vapour pressure versus temperature curve for the solution indicates that the freezing point ( $T_f$ ) is lower than the 0 °C. The depression in freezing temperature ( $\Delta T_f$ ) can be expressed as,  $\Delta T_f = T_f^o - T_f$ . The experimental results show that the depression in freezing point is directly proportional to the mol concentration of the solute particles.

Hence,

$$\Delta T_f \propto m$$

$$\Delta T_f = K_f m \dots\dots\dots(9.30)$$

Here, ‘m’ = is the molality of the solution

$K_f$  = molal freezing point depression constant or cryoscopic constant.

If  $m=1$  then  $\Delta T_f = K_f$

The  $K_f$  is equal to the depression in freezing point for 1 molal solution

**Table 9.4 Molal freezing point depression constant for some solvents**

S. No.	Solvent	Freezing	$K_f$ (K.kg.
--------	---------	----------	--------------

		point (K)	mol <sup>-1</sup> )
1.	Water	273.0	1.86
2.	Ethanol	155.7	1.99
3.	Benzene	278.6	5.12
4.	Chloroform	209.6	4.79
5.	Carbon disulphide	164.2	3.83
6.	Ether	156.9	1.79
7.	Cyclohexane	279.5	20.0
8.	Acetic acid	290.0	3.90

### Determination of molar mass of solute from depression in freezing point

If the solution is prepared by dissolving  $w_B$  g of solute in  $w_A$  g of solvent. Then depression in freezing point is given by (9.31)

$$\Delta T_f = \frac{K_f \times w_B \times 1000}{M_a \times w_A} \quad \dots\dots\dots(9.31)$$

molar mass of a solute can be calculated using (9.31)

$$M_a = \frac{K_f \times w_B \times 1000}{\Delta T_f \times w_A} \quad \dots\dots\dots(9.32)$$

### Example Problem - 5

Ethylene glycol (C<sub>2</sub> H<sub>6</sub> O<sub>2</sub>) can be used as an antifreeze in the radiator of a car. Calculate the temperature when ice will begin to separate from a mixture with 20 mass percent of glycol in water used in the car radiator.  $K_f$  for water = 1.86 K Kg mol<sup>-1</sup> and molar mass of ethylene glycol is 62 g mol<sup>-1</sup>.

Weight of solute ( $W_2$ ) = 20 mass percent of solution means 20 g of ethylene glycol

Weight of solvent (water)  $W_1 = 100 - 20 = 80$  g

$$\begin{aligned} \Delta T_f &= K_f m \\ &= \frac{K_f \times W_2 \times 1000}{62 \times 80} \\ &= \frac{1.86 \times 20 \times 1000}{62 \times 80} \\ &= 7.5 K \end{aligned}$$

The temperature at which ice will begin to separate is the freezing point of water after the addition of solute i.e 7.5 K lower than the normal freezing point of water (273-7.5K) = 265.5 K

### Osmosis and osmotic pressure

Many biological processes depend on osmosis, which is a spontaneous process by which the solvent molecules pass through a semi permeable membrane from a solution of lower concentration to a solution of higher concentration. The name osmosis is derived from the Greek word 'osmos' which means 'to push'. It is also important to know that the semipermeable membrane selectively allows certain molecules in the solution to pass through it but not others.

#### Osmosis and osmotic pressure

Let us consider a simple apparatus as shown in the above figure. A semipermeable membrane separates a chamber into two compartments. Water (pure solvent) is added to the first compartment and the aqueous NaCl (solution) is added to the second compartment such that the liquid levels on the both sides are equal. Since there is a difference in concentration between the liquids present in the two compartments, the water molecules move from first compartment to second compartment through the semipermeable membrane. The membrane allows only water molecules to pass through it in either direction but not NaCl. The net flow of water is into the sodium chloride solution and hence increases its volume. This decreases its concentration and also creates a pressure difference between the compartments. This pressure difference, push some of the water molecules back to the solvent side through the semipermeable membrane until an equilibrium is established. At the equilibrium, the rate of movement of solvent molecules on both directions are equal. The pressure difference at the equilibrium is called osmotic pressure ( $\pi$ ). Thus, osmotic pressure can be defined as "the pressure that must be applied to the solution to stop the influx of the solvent (to stop osmosis) through the semipermeable membrane"

van't Hoff found out that for dilute solutions, the osmotic pressure is directly proportional to the molar concentration of the solute and the temperature of the solution. He proposed the following equation to calculate osmotic pressure which is now called as van't Hoff equation.

$$\pi = CRT \text{ ----- } 9.31$$

Here,

C = Concentration of the solution in molarity

T = Temperature

R = Gas constant

### Determination of molar mass from osmotic pressure

According to van't Hoff equation

$$\pi = CRT$$

$$C = \frac{n}{V}$$

Here, n = number of moles of solute dissolved in 'V' litre of the solution. Therefore,

$$\pi = \frac{n}{V} RT \text{ or}$$

$$\pi V = nRT \text{ ----- (9.33)}$$

If the solution is prepared by dissolving  $w_B$  g of nonvolatile solute in  $w_A$  g of solvent, then the number of moles of solute (n) is,

$$n = \frac{w_B}{M_B}$$

Here,  $M_B$  = molar mass of the solute Substituting the 'n' in (9.33), we get,

$$\pi = \frac{w_B}{V} \frac{RT}{M_B}$$

$$M_B = \frac{w_B}{V} \frac{RT}{\pi}$$

From the equation 9.33, molar mass of the solute can be calculated.

### Significances of osmotic pressure over other colligative properties

Unlike elevation of boiling point (for 1 molal solution the elevation in boiling point is 0.512 °C for water) and the depression in freezing point (for 1 molal solution the depression in freezing point is 1.86 °C for water), the magnitude of osmotic pressure is large.

The osmotic pressure can be measured at room temperature enables to determine the molecular mass of biomolecules which are unstable at higher temperatures.

Even for a very dilute solution, the osmotic pressure is large.

### Isotonic solutions

Two solutions having same osmotic pressure at a given temperature are called isotonic solutions. When such solutions are separated by a semipermeable membrane, solvent flow between one to the other on either direction is same, i.e. the net solvent flow between the two isotonic solutions is zero.

The osmotic pressure of the blood cells is approximately equal to 7 atm at 37°C. The intravenous injections should have same osmotic pressure as that of the blood (isotonic with blood). If the Intravenous solutions are too dilute that is hypotonic, the solvent from outside of the cells will flow into the cell to normalise the osmotic pressure and this process which is called hemolysis, causes the cells to burst. On the other hand, if the solution is too concentrated, that is hypertonic, the solvent molecules will flow out of the cells, which causes the cells to shrink and die. For this reason, the Intravenous fluids are prepared such they are isotonic to blood (0.9 % mass/ volume sodium chloride solution).

### Reverse osmosis (RO):

Let us consider the experimental setup (Figure 9.15) discussed in the osmosis. The pure water moves through the semipermeable membrane to the NaCl solution due to osmosis. This process can be reversed by applying pressure greater than the osmotic pressure to the solution side. Now the pure water moves from the solution side to the solvent side and this process is called reverse osmosis. It can be defined as a process in which a solvent passes through a semipermeable membrane in the opposite direction of osmosis, when subjected to a hydrostatic pressure greater than the osmotic pressure.

### Application of Reverse osmosis in water purification:

#### Osmosis & Reverse osmosis

Reverse osmosis is used in the desalination of sea water and also in the purification of drinking water. A simple set up used in both the process is shown in the figure 9.15. When a pressure higher than the osmotic pressure is applied on the solution side (sea water) the water molecules moves from solution side to the solvent side through semipermeable membrane (Opposite to the Osmotic flow). Pure water can be collected. There are different types of semipermeable membranes used in this process. The membrane used for reverse osmosis has to withstand high pressures. Generally, cellulose acetate or polyamide membranes are commonly used in commercial systems. The selection of membrane used for reverse osmosis will be decided based on the nature of the input water.

### Example Problem-6:

At 400K 1.5 g of an unknown substance is dissolved in a solvent and the solution is made to 1.5 L. Its osmotic pressure is found to be 0.3 bar. Calculate the molar mass of the unknown substance.



$$\begin{aligned} \text{Molar mass} &= \frac{\text{mass of unknown solute} \times RT}{\text{osmotic pressure} \times \text{volume of solution}} \\ &= \frac{1.5 \times 8.314 \times 10^{-2} \times 400}{0.3 \times 1.5} \\ &= 110.85 \text{ gram mol}^{-1} \end{aligned}$$

### Abnormal molar mass

The molar masses of the nonvolatile solutes can be calculated accurately using the experimentally determined colligative properties. In this method, we assume that the solution is very dilute and there is no dissociation or association of solute particles in the solution. In a concentrated solution, the interaction between the solute and solvent becomes significant and reflected in the measured colligative properties. Similarly, the dissociation or association of solute molecules would alter the total number of particles present in the solution and hence affect the results of measured colligative properties. In such solutions, the value of the molar mass of the solute determined using colligative properties would be different from the actual molar mass, and it is called abnormal molar mass.

### Association or dissociation of solute molecules:

Normally, the molar mass determination using measured colligative properties assumes that the solute does not dissociate or associate. In certain solvents, solute molecules associate to form a dimer or trimer etc... This reduces the total number of particles (molecules) formed in solution and as a result the calculated molar mass will be higher than the actual molar mass. Let us consider a solution of acetic acid in benzene. It is already established that acetic acid forms inter molecular hydrogen bonds as shown in the figure 9.9 and exists as a dimer in benzene.

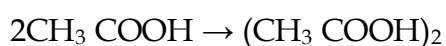

The molar mass of acetic acid calculated using colligative properties is found to be around 120 g mol<sup>-1</sup> is two times the actual molar mass (60 g mol<sup>-1</sup>).

The electrolytes such as KCl or NaCl dissociates completely into its constituent ions in their aqueous solution. This causes an increase in the total number of particles (ions) present in the solution. The calculated molar mass using colligative property measurement for this type of solutions will be lower than the actual molar mass. For example, sodium chloride dissociates into Na<sup>+</sup> ions and Cl<sup>-</sup> ions in aqueous solution, as shown below.

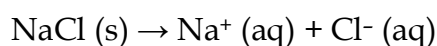

When we dissolve 1 mole of NaCl (58.4 g) in water, it dissociates and gives 1 mole of Na<sup>+</sup> and 1 mole of Cl<sup>-</sup>. Hence, the solution will have 2 moles of particles. Thus, the colligative properties would be double the expected value.

### van't Hoff factor

We have learnt that the dissociation or association of solute molecules in a solution will result in the increase or decrease in the calculated molar mass using the colligative property. This variation is proportional to the extent of association or dissociation. To quantify the extent of association or dissociation of solutes in solution, van't Hoff introduced a term 'i' which is now called van't Hoff factor. It is defined as the ratio of the actual molar mass to the abnormal (calculated) molar mass of the solute. Here, the abnormal molar mass is the molar mass calculated using the experimentally determined colligative property.

$$i = \frac{\text{Normal (actual) molar mass}}{\text{Observed (abnormal) molar mass}}$$

$$= \frac{\text{Observed colligative property}}{\text{Calculated colligative property}}$$

The estimated Van't Hoff factor for acetic acid solution in Benzene is 0.5 and that of sodium chloride solution in water is 2. The degree of dissociation or association can be related to Van't Hoff factor (i) using the following relationships

$$\alpha_{\text{dissociation}} = \frac{i - 1}{n - 1}$$

(Where n is number ions / species formed by the dissociation of a single molecule)

$$\alpha_{\text{association}} = \frac{(1 - i)n}{n - 1}$$

(Here, n is the number of solute involved in association.)

The equations relating the four colligative properties with the concentration of the solutes can be rewritten as follows by incorporating the van't Hoff factor

Relative lowering of vapour pressure,

$$= \frac{P_{\text{solvent}}^{\circ} - P_{\text{solution}}}{P_{\text{solvent}}^{\circ}} = i \frac{n_{\text{solute}}}{n_{\text{solvent}}}$$

Elevation of boiling point,

$$\Delta T_b = i K_b m$$

Depression in the freezing point,

$$\Delta T_f - iK_f m$$

Osmotic pressure,

$$\pi = i \frac{W_{solute}}{V} \frac{RT}{M_{solute}}$$

For a solute that does not dissociate or associate the van't Hoff factor is equal to 1 ( $i = 1$ ) and the molar mass will be close to the actual molar mass.

For the solutes that associate to form higher oligomers in solution the van't Hoff factor will be less than one ( $i < 1$ ) and the observed molar mass will be greater than the actual molar mass.

For the solutes that associate to form higher oligomers in solution the van't Hoff factor will be less than one ( $i > 1$ ) and the observed molar mass will be less than the normal molar mass.

### Example Problem - 7

The depression in freezing point is 0.24K obtained by dissolving 1g NaCl in 200g water. Calculate van't-Hoff factor. The molal depression constant is 1.86 K Kg mol<sup>-1</sup>

Molar mass of solute

$$= \frac{1000 \times K_f \times \text{mass of NaCl}}{\Delta T_f \times \text{mass solvent}}$$

$$= \frac{1000 \times 1.86 \times 1}{0.24 \times 200}$$

$$= 38.75 \text{ g mol}^{-1}$$

$$= 38.75 \text{ g mol}$$

Theoretical molar mass of NaCl is =

$$i = \frac{\text{Theoretical molar mass}}{\text{Experimental molar mass}} = \frac{58.5}{38.75}$$

$$= 1.50$$

## Unit 10

### Chemical Bonding

**Linus Carl Pauling** was an American chemist, biochemist, peace activist, author and educator. In addition to his contribution to chemistry and he also worked with many biologists. He received the Nobel Prize in Chemistry in 1954 for his research into the nature of the chemical bond and its application to the elucidation of the structure of complex substances.

#### Introduction

Diamond is very hard while its allotrope graphite is very soft. Gases like hydrogen and oxygen are diatomic while the inert gases are monoatomic.

Carbon combines with chlorine to form carbon tetrachloride, which is a liquid and insoluble (immiscible) in water. Sodium combines with chlorine atom to form sodium chloride, a hard and brittle compound that readily dissolves in water. The possible reason for these observations lies in the type of interaction that exists between the atoms of these molecules and these interactions are responsible for holding the atoms/ions together. The interatomic attractive forces which hold the constituent atoms/ions together in a molecule are called chemical bonds.

Why do atoms combine only in certain combinations to form molecules? For example oxygen combines with hydrogen to give water ( $\text{H}_2\text{O}$ ) and with carbon it gives carbon dioxide ( $\text{CO}_2$ ). The structure of water is 'V' shaped while that of the carbon dioxide is linear. Such questions can be answered using the principles of chemical bonding. In this unit we will analyse the various theories and their principles, which were developed over the years to explain the nature of chemical bonding.

#### Kossel - Lewis approach to chemical bonding

A logical explanation for chemical bonding was provided by Kossel and Lewis in 1916. Their approach to chemical bonding is based on the inertness of the noble gases which have little or no tendency to combine with other atoms. They proposed that the noble gases are stable due to their completely filled outer shell electronic configuration. Elements other than noble gases, try to attain the completely filled electronic configurations by losing, gaining or sharing one or more electrons from their outer shell. For example, sodium loses one electron to form  $\text{Na}^+$  ion and chlorine accepts that electron to give chloride ion ( $\text{Cl}^-$ ), enabling both atoms to attain the nearest noble gas configuration. The resultant ions,  $\text{Na}^+$  and

Cl<sup>-</sup> are held together by electrostatic attractive forces and the attractive force is called a chemical bond, more specifically an electrovalent bond.

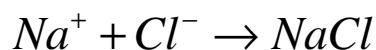
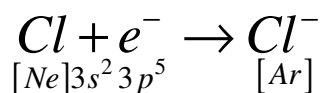
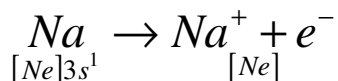

G. N. Lewis proposed that the attainment of stable electronic configuration in molecules such as diatomic nitrogen, oxygen etc... is achieved by mutual sharing of the electrons. He introduced a simple scheme to represent the chemical bond and the electrons present in the outer shell of an atom, called Lewis dot structure. In this scheme, the valence electrons (outer shell electrons) of an element are represented as small dots around the symbol of the element. The first four valence electrons are denoted as single dots around the four sides of the atomic symbol and then the fifth onwards, the electrons are denoted as pairs. For example, the electronic configuration of nitrogen is 1s<sup>2</sup>, 2s<sup>2</sup>, 2p<sup>3</sup>. It has 5 electrons in its outer shell (valence shell). The Lewis structure of nitrogen is as follows.

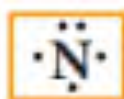

**Lewis Structure of Nitrogen atom**

Similarly, Lewis dot structure of carbon, oxygen can be drawn as shown below.



**Lewis Structures of C & O atoms**

Only exception to this is helium which has only two electrons in its valence shell which is represented as a pair of dots (duet).



**Lewis Structures of He atom Octet rule**

The idea of Kossel - Lewis approach to chemical bond lead to the octet rule, which states that **“the atoms transfer or share electrons so that all atoms involved in chemical bonding obtain 8 electrons in their outer shell (valence shell)”**.

### Types of chemical bonds

The chemical bonds can be classified based on the nature of the interaction between the bonded atoms. Two major types of chemical bonds are covalent bonds and ionic bonds. Generally metals reacts with non-metals to form ionic compounds, and the covalent bonds are present in the compounds formed by nonmetals.

### Covalent bonds:

Do you know all elements (except noble gases) occurs either as compounds or as polyatomic molecules? Let us consider hydrogen gas in which two hydrogen atoms bind to give a dihydrogen molecule. Each hydrogen atom has one electron and it requires one more electron to attain the electronic configuration of the nearest noble gas helium. Lewis suggested that both hydrogen atoms will attain the stable configuration by mutually sharing the electrons available with them. Similarly, in the case of oxygen molecule, both the oxygen atoms share two electron pairs between them and in nitrogen molecule three electron pairs are shared between two nitrogen atoms. **This type of mutual sharing of one or more pairs of electrons between two combining atoms results in the formation of a chemical bond called a covalent bond.** If two atoms share just one pair of electron a single covalent bond is formed as in the case of hydrogen molecule. If two or three electron pairs are shared between the two combining atoms, then the covalent bond is called a double bond or a triple bond, respectively.

### Representation of Lewis Structures of covalent bonds

#### Representing a covalent bond - Lewis structure (Lewis dot structure)

Lewis structure (Lewis dot structure) is a pictorial representation of covalent bonding between the combining atoms. In this structure the shared valence electrons are represented as a pair of dots between the combining atoms and the unshared electrons of the atoms are represented as a pair of dots (lone pair) on the respective individual atoms.

The Lewis dot structure for a given compound can be written by following the steps given below. Let us understand these steps by writing the Lewis structure for water.

1. **Draw the skeletal structure of the molecule.** In general, the less electronegative atom is placed at the centre. Hydrogen and fluorine atoms should be placed at the terminal positions. For water, the skeletal structure is



2. **Calculate the total number of valence electrons of all the atoms in the molecule.** In case of polyatomic ions the charge on ion should also be considered during the calculation of the total number of valence electrons. In case of anions the number of negative charges should be added to the number of valence electrons. For positive ions the total number of positive charges should be subtracted from the total number of valence electrons.

In water, total number of valence electron =  $[2 \times 1 \text{ (valence electron of hydrogen)}] + [1 \times 6 \text{ (valence electrons of oxygen)}] = 2 + 6 = 8$ .

3. **Draw a single bond between the atoms in the skeletal structure of the molecule.** Each bond will account for two valence electrons (a bond pair). For water, we can draw two bonds accounting for four valence electrons as follows.

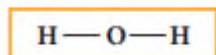

4. **Distribute the remaining valence electrons as pairs (lone pair), giving octet (only duet for hydrogen) to the atoms in the molecule.** The distribution of lone pairs starts with the most electronegative atoms followed by other atoms.

In case of water, the remaining four electrons (two lone pairs) are placed on the most electronegative central oxygen, giving octet.

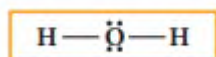

5. **Verify whether all the atoms satisfy the octet rule (for hydrogen duet).** If not, use the lone pairs of electrons to form additional bond to satisfy the octet rule. In case of water, oxygen has octet and the hydrogens have duets, hence there is no need for shifting the lone pairs. The Lewis structure of water is as follows

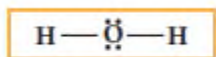

Lewis structure of water

Let us draw the Lewis structure for nitric acid.

1. Skeletal structure

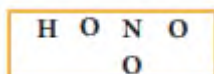

2. Total number of valence electrons in

$$\begin{aligned} \text{HNO}_3 &= [1 \times 1 \text{ (hydrogen)}] + [1 \times 5 \text{ (nitrogen)}] + [3 \times 6 \text{ (oxygen)}] \\ &= 1 + 5 + 18 = 24 \end{aligned}$$

3. Draw single bonds between atoms. Four bonds can be drawn as shown in the figure for HNO<sub>3</sub> which account for eight electrons (4 bond pairs).





Formal charge:

Let us draw the Lewis structure for carbon dioxide.

1. Skeletal structure



2. Total number of valence electrons in

CO<sub>2</sub>

$$= [1 \times 4(\text{carbon})] + [2 \times 6(\text{oxygen})]$$

$$= 4 + 12 = 16$$

3. Draw single bonds between atoms. Two bonds can be drawn as shown in the figure for CO<sub>2</sub> which accounts for four electrons (2 bond pairs).

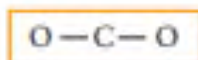

4. Distribute the remaining twelve electrons (16 - 4 = 12) as six lone pairs starting from most electronegative atom, the oxygen. Six lone pairs are distributed to the two terminal oxygens (three each) to satisfy their octet.

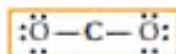

5. Verify whether all the atoms have octet configuration. In the above distribution, the central carbon has two pairs short for octet. Therefore, to satisfy the octet rule two lone pairs from one oxygen or one pair from each oxygen can be moved to form multiple bonds, leading to the formation of two possible structures for carbon dioxide as shown below

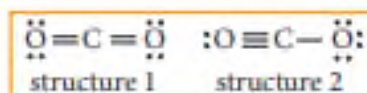

#### two possible structures for carbon dioxide

Similarly, the Lewis structure for many molecules drawn using the above steps gives more than one acceptable structure. Let us consider the above mentioned two structures of carbon dioxide.

Which one of the above forms represents the best distribution of electrons in the molecule. To find an answer, we need to know the formal charge of each atom in the Lewis structures. Formal charge of an atom in a molecule, is the electrical charge difference between the valence electron in an isolated atom and the number of electrons assigned to that atom in the Lewis structure.

$$\text{Formal charge of an atom} = N_v - \left( N_l + \frac{N_b}{2} \right)$$

Where,

$N_v$  - Number of valence electron of atom in its isolated state.

$N_l$  - Number of electrons present as lone pairs around the atom in the Lewis structure

$N_b$  - Number of electrons present in bonds around the atom (bond pairs) in the Lewis structure]

Now let us calculate the formal charge on all atoms in both structures,

For Structure 1,

$$\begin{aligned} \text{Formal charge on carbon} &= N_v - \left( N_l + \frac{N_b}{2} \right) \\ &= 4 - \left( 0 + \frac{8}{2} \right) = 0 \end{aligned}$$

$$\begin{aligned} \text{Formal charge on oxygen} &= 6 - \left( 4 + \frac{4}{2} \right) \\ &= 0 \text{ (for both oxygens)} \end{aligned}$$

**For structure 2**

Formal charge on carbon

$$\begin{aligned} &= N_v - \left( N_l + \frac{N_b}{2} \right) \\ &= 4 - \left( 0 + \frac{8}{2} \right) = 0 \end{aligned}$$

Formal charge on singly bonded oxygen

$$= 6 - \left( 6 + \frac{2}{2} \right) = -1$$

Formal charge on triply bonded oxygen

$$= 6 - \left( 2 + \frac{2}{2} \right) = +1$$

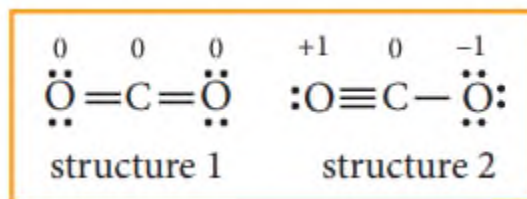

### two possible structures for carbon dioxide (with formal charges)

After calculating the formal charges, the best representation of Lewis structure can be selected by using following guidelines.

1. A structure in which all formal charges are zero preferred over the one with charges.
2. A structure with small formal charges is preferred over the one with higher formal charges.
3. A structure in which negative formal charges are placed on the most electronegative atom is preferred.

In case of CO<sub>2</sub> structures, the structure one is preferred over the structure 2 as it has zero formal charges for all atoms.

### Lewis structures for exceptions to octet rule

The octet rule is useful for writing Lewis structures for molecules with second period element as central atoms. In some molecules, the central atoms have less than eight electrons around them while some others have more than eight electrons. Exception to the octet rule can be categorized into following three types.

1. Molecules with electron deficient central atoms
2. Molecules containing odd electrons
3. Molecules with expanded valence shells

### Molecules with electron deficient central atoms

Let us consider boron trifluoride, as an example. The central atom boron has three valence electron and each fluorine has seven valence electrons. The Lewis structure is

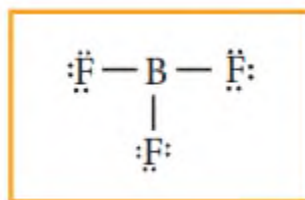

**Lewis structure of BF<sub>3</sub>**

In the above structure, only six electrons around boron atom. Moving a lone pair from one of the fluorine to form additional bond as shown below.

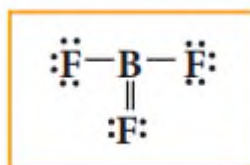

**Lewis structure of BF<sub>3</sub>**

However, the above structure is unfavourable as the most electronegative atom fluorine shows positive formal charge and hence the structure with incomplete octet is the favourable one. Molecules such as BCl<sub>3</sub>, BeCl<sub>2</sub>, etc... also have incomplete octets.

### Molecules containing odd electrons

Few molecules have a central atom with an odd number of valence electrons. For example, in nitrogen dioxide and nitric oxide all the atoms does not have octet configuration. The lewisstructure of the above molecules are shown in the figure.

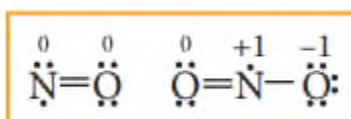

**Lewis structures of Nitric oxide and Nitrogen dioxide (with formal charges)**

### Molecules with expanded valence shells

In molecules such as sulphur hexafluoride (SF<sub>6</sub>), phosphorous pentachloride (PCl<sub>5</sub>) the central atom has more than eight valence electrons around them. Here the central atom can accommodate additional electron pairs by using outer vacant d orbitals. In SF<sub>6</sub> the central atom sulphur is surrounded by six bonding pair of electrons or twelve electrons.

### Lewis structures for SF<sub>6</sub> and PCl<sub>5</sub>

### Ionic or electrovalent bond

When the electronegativity difference between the two combining atoms is large, the least electronegative atom completely transfers one or more of its valence electrons to the other combining atom so that both atoms can attain the nearest inert gas electronic configuration. The complete transfer of electron leads to the formation of a cation and an anion. Both these ions are held together by the electrostatic attractive force which is known as ionic bond.

Let us consider the formation potassium chloride. The electronic configuration of potassium and chlorine are

Potassium (K): [Ar] 4s<sup>1</sup>

Chlorine (Cl): [Ne] 3s<sup>2</sup>, 3p<sup>5</sup>

Potassium has one electron in its valence shell and chlorine has seven electron in its valence shell. By losing one electron potassium attains the inert gas electronic configuration of argon and becomes a unipositivecation (K<sup>+</sup>) and chlorine accepts this electron to become uninegative chloride ion (Cl<sup>-</sup>) there by attaining the stable electronic configuration of argon. These two ions combine to form an ionic crystal in which they are held together by electrostatic attractive force. The energy required for the formation of one mole of K<sup>+</sup> is **418.81 kJ** (ionization energy) and the energy released during the formation of one mole of Cl<sup>-</sup> is **-348.56 kJ** (electron gain enthalpy). The sum of these two energies is positive (**70.25 kJ**) However, during the formation of one mole potassium chloride crystal from its constituent ions, 718 kJ energy is released. This favours the formation of KCl and its stability.

### Coordinate covalent bond

In the formation of a covalent bond, both the combining atoms contribute one electron each and the these electrons are mutually shared among them. However, in certain bond formation, one of the combining atoms donates a pair of electrons i.e. two electrons which are necessary for the covalent bond formation, and these electrons are shared by both the combining atoms. These type of bonds are called coordinate covalent bond or coordinate bond. The combining atom which donates the pair of electron is called a donor atom and the other atom an acceptor atom. This bond is denoted by an arrow starting from the donor atom pointing towards the acceptor atom. (Later in coordination compound, we will refer the donor atom as ligand and the acceptor atom as central-metal atom/ion.

For Example, in ferrocyanide ion [Fe(CN)<sub>6</sub>]<sup>4-</sup>, each cyanide ion (CN<sup>-</sup>) donates a pair of electrons to form a coordinate bond with iron (Fe<sup>2+</sup>) and these electrons are shared by Fe<sup>2+</sup> and CN<sup>-</sup>.

### Structure of Ferrocyanide ion

In certain cases, molecules having a lone pair of electrons such as ammonia donates its pair to an electron deficient molecules such as BF<sub>3</sub>. to form a coordinate

## Structure of $\text{BF}_3 \rightarrow \text{NH}_3$

### Bond parameters

A covalent bond is characterised by parameters such as bond length, bond angle, bond order etc... A brief description of some of the bond parameters is given below.

### Bond length

The distance between the nuclei of the two covalently bonded atoms is called bond length. Consider a covalent molecule A-B. The bond length is given by the sum of the radii of the bonded atoms

( $r_A + r_B$ ). The length of a bond can be determined by spectroscopic, x-ray diffraction and electron-diffraction techniques. The bond length depends on the size of the atom and the number of bonds (multiplicity) between the combining atoms.

### Bond length of covalent molecule A-B

Greater the size of the atom, greater will be the bond length. For example, carbon-carbon single bond length (1.54 Å) is longer than the carbon-nitrogen single bond length (1.43 Å). Increase in the number of bonds between the two atoms decreases the bond length. For example, the carbon-carbon single bond is longer than the carbon-carbon double bond (1.33 Å) and the carbon-carbon triple bond (1.20 Å).

### Bond order

The number of bonds formed between the two bonded atoms in a molecule is called the bond order. In Lewis theory, the bond order is equal to the number of shared pair of electrons between the two bonded atoms. For example in hydrogen molecules, there is only one shared pair of electrons and hence, the bond order is one. Similarly, in  $\text{H}_2\text{O}$ ,  $\text{HCl}$ , Methane, etc the central atom forms single bonds with bond order of one.

### Bond order of some common bonds:

S. No.	Molecule	Bonded atoms	Bond order (No. of shared pair of electrons between bonded atoms)
1	$\text{H}_2$	H-H	1
2	$\text{O}_2$	O=O	2
3	$\text{N}_2$	$\text{N}\equiv\text{N}$	3

4	HCN	$C \equiv N$	3
5	HCHO	$C=O$	2
6	CH <sub>4</sub>	$C-H$	1
7	C <sub>2</sub> H <sub>4</sub>	$C=C$	2

### Bond angle

Covalent bonds are directional in nature and are oriented in specific directions in space. This directional nature creates a fixed angle between two covalent bonds in a molecule and this angle is termed as bond angle. It is usually expressed in degrees. The bond angle can be determined by spectroscopic methods and it can give some idea about the shape of the molecule.

### Bond angles for some common molecules

S. No.	Molecule	Atoms defining the angle	Bond angle (°)
1	CH <sub>4</sub>	H-C-H	109° 28'
2	NH <sub>3</sub>	H-N-H	107° 18'
3	H <sub>2</sub> O	H-O-H	104° 35'

### Bond enthalpy

The bond enthalpy is defined as the minimum amount of energy required to break one mole of a particular bond in molecules in their gaseous state. The unit of bond enthalpy is kJ mol<sup>-1</sup>. Larger the bond enthalpy, stronger will be the bond. The bond energy value depends on the size of the atoms and the number of bonds between the bonded atoms. Larger the size of the atom involved in the bond, lesser is the bond enthalpy.

In case of polyatomic molecules with, two or more same bond types, in the term average bond enthalpy is used. For such bonds, the arithmetic mean of the bond energy values of the same type of bonds is considered as average bond enthalpy. For example in water, there are two OH bonds present and the energy needed to break them are not same.

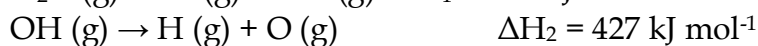
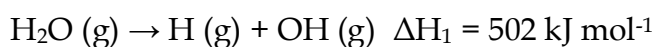

The average bond enthalpy of OH bond in water =  $\frac{502 + 427}{2} = 464.5 \text{ kJ mol}^{-1}$

**Bond lengths and bond enthalpies of some common bonds:**

S. No.	Bond type	Bond Enthalpy (kJ mol <sup>-1</sup> )	Bond Length (Å)
1	H-H	432	0.74
2	H-F	565	0.92
3	H-Cl	427	1.27
4	H-Br	363	1.41
5	H-I	295	1.61
6	C-H	413	1.09
7	C-C	347	1.54
8	C-Si	301	1.84
9	C-N	305	1.47
10	C-O	358	1.43
11	C-P	264	1.87
12	C-S	259	1.81
13	C-F	453	1.33
14	C-Cl	339	1.77
15	C-Br	276	1.94
16	C-I	216	2.13

**Resonance**

When we write Lewis structures for a molecule, more than one valid Lewis structures are possible in certain cases. For example let us consider the Lewis structure of carbonate ion [CO<sub>3</sub>]<sup>2-</sup>.

The skeletal structure of carbonate ion (The oxygen atoms are denoted as O<sub>A</sub>, O<sub>B</sub>& O<sub>C</sub>



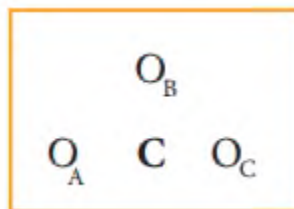

Total number of valence electrons = [1 × 4(carbon)] + [3 × 6 (oxygen)] + [2 (charge)] = 24 electrons.

Distribution of these valence electrons gives us the following structure.

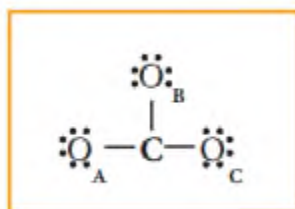

Complete the octet for carbon by moving a lone pair from one of the oxygens (O<sub>A</sub>) and write the charge of the ion (2-) on the upper right side as shown in the figure.

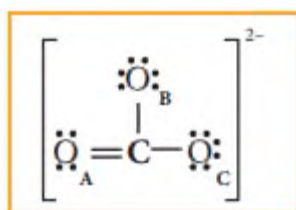

Lewis Structure of CO<sub>3</sub><sup>2-</sup>

In this case, we can draw two additional Lewis structures by moving the lone pairs from the other two oxygens (O<sub>B</sub> and O<sub>C</sub>) thus creating three similar structures as shown below in which the relative position of the atoms are same. They only differ in the position of bonding and lone pair of electrons. Such structures are called resonance structures (canonical structures) and this phenomenon is called resonance.

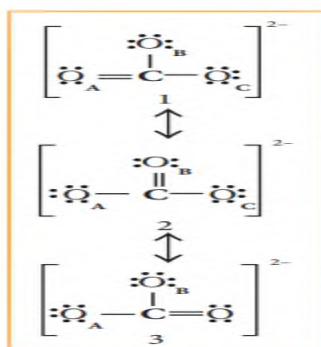

Resonance structures of CO<sub>3</sub><sup>2-</sup>

It is evident from the experimental results that all carbon-oxygen bonds in carbonate ion are equivalent. The actual structure of the molecules is said to be the resonance hybrid, an average of these three resonance forms. It is important to note that carbonate ion does not change from one structure to another and vice versa. It is not possible to picturise the resonance hybrid by drawing a single Lewis structure. However, the following structure gives a qualitative idea about the correct structure.

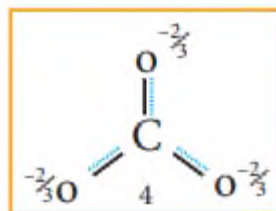

**Resonance Hybrid structures of  $CO_3^{2-}$**

It is found that the energy of the resonance hybrid (structure 4) is lower than that of all possible canonical structures (Structure 1, 2 & 3). The difference in energy between structure 1 or 2 or 3, (most stable canonical structure) and structure 4 (resonance hybrid) is called resonance energy.

### **Polarity of Bonds**

Partial ionic character in covalent bond:

When a covalent bond is formed between two identical atoms (as in the case of  $H_2$ ,  $O_2$ ,  $Cl_2$  etc...) both atoms have equal tendency to attract the shared pair of electrons and hence the shared pair of electrons lies exactly in the middle of the nuclei of two atoms. However, in the case of covalent bond formed between atoms having different electronegativities, the atom with higher electronegativity will have greater tendency to attract the shared pair of electrons more towards itself than the other atom. As a result the cloud of shared electron pair gets distorted.

Let us consider the covalent bond between hydrogen and fluorine in hydrogen fluoride. The electronegativities of hydrogen and fluorine on Pauling's scale are 2.1 and 4 respectively. It means that fluorine attracts the shared pair of electrons approximately twice as much as the hydrogen which leads to partial negative charge on fluorine and partial positive charge on hydrogen. Hence, the H-F bond is said to be polar covalent bond.

Here, a very small, equal and opposite charges are separated by a small distance (91 pm) and is referred to as a dipole.

Dipole moment:

The polarity of a covalent bond can be measured in terms of dipole moment which is defined as

$$\mu = q \times 2d$$

Where  $\mu$  is the dipole moment,  $q$  is the charge and  $2d$  is the distance between the two charges. The dipole moment is a vector and the direction of the dipole moment vector points from the negative charge to positive charge.

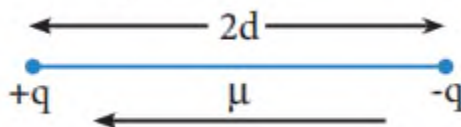

### Representation of Dipole

The unit for dipole moment is coulomb meter (C m). It is usually expressed in Debye unit (D). The conversion factor is  $1 \text{ Debye} = 3.336 \times 10^{-30} \text{ C m}$

Diatomic molecules such as  $\text{H}_2$ ,  $\text{O}_2$ ,  $\text{F}_2$  etc... have zero dipole moment and are called non polar molecules and molecules such as HF, HCl, CO, NO etc... have non zero dipole moments and are called polar molecules.

Molecules having polar bonds will not necessarily have a dipole moment. For example, the linear form of carbon dioxide has zero dipole moment, even though it has two polar bonds. In  $\text{CO}_2$ , the dipole moments of two polar bonds (CO) are equal in magnitude but have opposite direction. Hence, the net dipole moment of the  $\text{CO}_2$  is,

$$\mu = \mu_1 + \mu_2 = \mu_1 + (-\mu_1) = 0$$

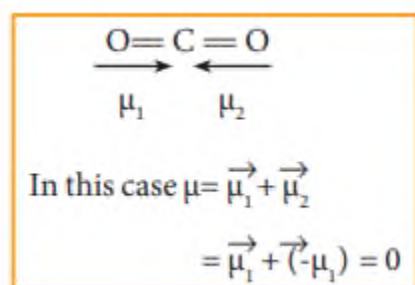

In case of water net dipole moment is the vector sum of  $\mu_1 + \mu_2$  as shown.

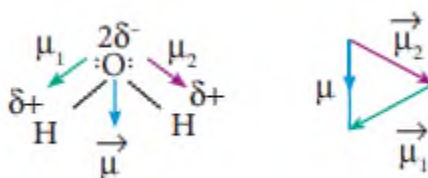

### Dipole moment in water

Dipole moment in water is found to be 1.85D

### Dipole moments of common molecules

S. No.	Molecule	Dipole moment (in
--------	----------	-------------------

		D)
1	HF	1.91
2	HCl	1.03
3	H <sub>2</sub> O	1.85
4	NH <sub>3</sub>	1.47
5	CHCl <sub>3</sub>	1.04

The extent of ionic character in a covalent bond can be related to the electro negativity difference to the bonded atoms. In a typical polar molecule, A<sup>δ-</sup>-B<sup>δ+</sup>, the electronegativity difference ( $\chi_A - \chi_B$ ) can be used to predict the percentage of ionic character as follows.

If the electronegativity difference ( $\chi_A - \chi_B$ ), is equal to 1.7, then the bond A-B has 50% ionic character

if it is greater than 1.7, then the bond A-B has more than 50% ionic character,

and if it is lesser than 1.7, then the bond A-B has less than 50% ionic character.

#### Partial covalent character in ionic bonds:

Like the partial ionic character in covalent compounds, ionic compounds show partial covalent character. For example, the ionic compound, lithium chloride shows covalent character and is soluble in organic solvents such as ethanol.

The partial covalent character in ionic compounds can be explained on the basis of a phenomenon called polarisation. We know that in an ionic compound, there is an electrostatic attractive force between the cation and anion. The positively charged cation attracts the valence electrons of anion while repelling the nucleus. This causes a distortion in the electron cloud of the anion and its electron density drifts towards the cation, which results in some sharing of the valence electrons between these ions. Thus, a partial covalent character is developed between them. This phenomenon is called polarisation.

The ability of a cation to polarise an anion is called its polarising ability and the tendency of an anion to get polarised is called its polarisability. The extent of polarisation in an ionic compound is given by the Fajans rules

#### Fajans Rules

- (i) To show greater covalent character, both the cation and anion should have high charge on them. Higher the positive charge on the cation, greater will be the attraction on the electron cloud of the anion. Similarly higher the magnitude of

negative charge on the anion, greater is its polarisability. Hence, the increase in charge on cation or in anion increases the covalent character

Let us consider three ionic compounds aluminum chloride, magnesium chloride and sodium chloride. Since the charge of the cation increase in the order  $\text{Na}^+ < \text{Mg}^{2+} < \text{Al}^{3+}$ , the covalent character also follows the same order  $\text{NaCl} < \text{MgCl}_2 < \text{AlCl}_3$ .

- (ii) The smaller cation and larger anion show greater covalent character due to the greater extent of polarisation. Lithium chloride is more covalent than sodium chloride. The size of  $\text{Li}^+$  is smaller than  $\text{Na}^+$  and hence the polarising power of  $\text{Li}^+$  is more. Lithium iodide is more covalent than lithium chloride as the size of  $\text{I}^-$  is larger than the  $\text{Cl}^-$ . Hence  $\text{I}^-$  will be more polarised than  $\text{Cl}^-$  by the cation,  $\text{Li}^+$ .
- (iii) Cations having  $ns^2 np^6 nd^{10}$  configuration show greater polarising power than the cations with  $ns^2 np^6$  configuration. Hence, they show greater covalent character.

$\text{CuCl}$  is more covalent than  $\text{NaCl}$ . Compared to  $\text{Na}^+$  (1.13 Å).  $\text{Cu}^+$  (0.6 Å) is small and have  $3s^2 3p^6 3d^{10}$  configuration. Electronic configuration of  $\text{Cu}^+$

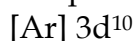

Electronic Configuration of  $\text{Na}^+$

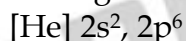

### Valence Shell Electron Pair Repulsion (VSEPR) theory

Lewis concept of structure of molecules deals with the relative position of atoms in the molecules and sharing of electron pairs between them. However, we cannot predict the shape of the molecule using Lewis concept. Lewis theory in combination with VSEPR theory will be useful in predicting the shape of molecules.

#### Important principles of VSEPR Theory are as follows:

1. The shape of the molecules depends on the number of valence shell electron pair around the central atom.
2. There are two types of electron pairs namely bond pairs and lone pairs. The bond pair of electrons are those shared between two atoms, while the lone pairs are the valence electron pairs that are not involved in bonding.
3. Each pair of valence electrons around the central atom repels each other and hence, they are located as far away as possible in three dimensional space to minimize the repulsion between them.
4. The repulsive interaction between the different types of electron pairs is in the following order.





lp - lp > lp - bp > bp-bp  
lp- lone pair ; bp- bond pair

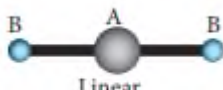
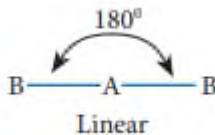
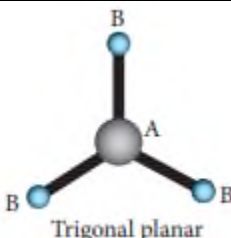
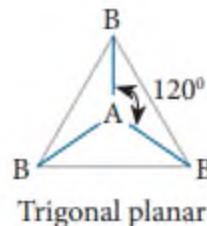
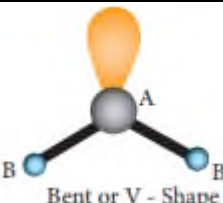
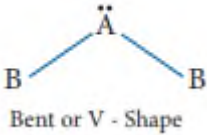

The lone pair of electrons are localised only on the central atom and interacts with only one nucleus whereas the bond pairs are shared between two atoms and they interact with two nuclei. Because of this the lone pairs occupy more space and have greater repulsive power than the bond pairs in a molecule.

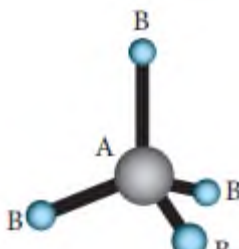
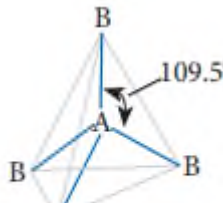
The following Table illustrates the shapes of molecules predicted by VSEPR theory. Consider a molecule  $AB_x$  where A is the central atom and x represents the number of atoms of B covalently bonded to the central atom A. The lone pairs present in the atoms are denoted as L.

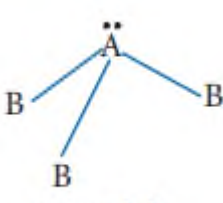
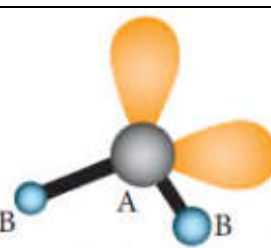
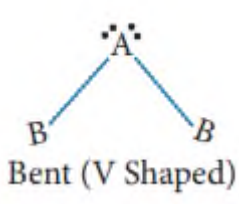
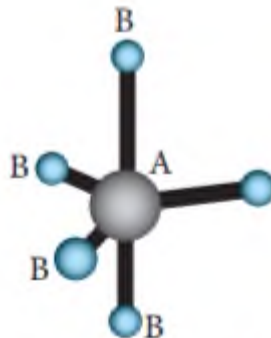
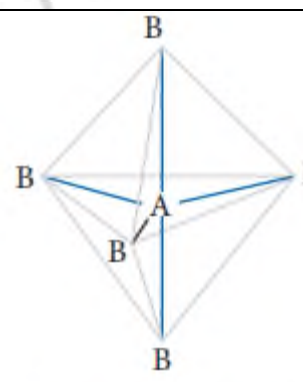
### Shapes of molecules predicted by VSEPR theory.

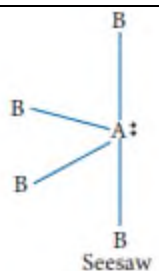
Number of electron Pairs	Molecule	No. of bond pairs	No. of. Lone pairs	Shape	Molecular geometry	Examples
2	$AB_2$	2	-	 <p style="text-align: center;">Linear</p>	 <p style="text-align: center;">Linear</p>	$BeCl_2$ , $HgCl_2$ , $CO_2$ , $CS_2$ , $HCN$ , $BeF_2$
3	$AB_3$	3	-	 <p style="text-align: center;">Trigonal planar</p>	 <p style="text-align: center;">Trigonal planar</p>	$BF_3$ , $BCl_3$ , $NO_3^-$ , $BF_3$ , $CO_3^{2-}$ , $HCHO$
	$AB_2L$	2	1	 <p style="text-align: center;">Bent or V - Shape</p>	 <p style="text-align: center;">Bent or V - Shape</p>	$SO_2$ , $O_3$ , $PbCl_2$ , $SnBr_2$

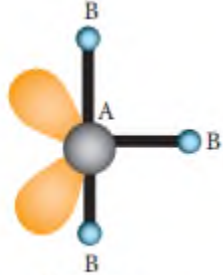
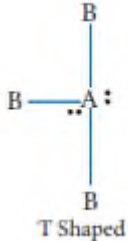
4	AB <sub>4</sub>	4	-	 <p>Tetrahedral</p>	 <p>Tetrahedral</p>	CH <sub>4</sub> , CCl <sub>4</sub> , CCl <sub>2</sub> F <sub>2</sub> , SO <sub>4</sub> <sup>2-</sup> , ClO <sub>4</sub> <sup>-</sup> , NH <sub>4</sub> <sup>+</sup>
	AB <sub>3</sub> L	3	1	 <p>pyramidal</p>	 <p>pyramidal</p>	NH <sub>3</sub> , PF <sub>3</sub> , ClO <sub>3</sub> <sup>-</sup> , H <sub>3</sub> O <sup>+</sup> ,
	AB <sub>2</sub> L <sub>2</sub>	2	2	 <p>Bent (V Shaped)</p>	 <p>Bent (V Shaped)</p>	H <sub>2</sub> O, OF <sub>2</sub> , SCl <sub>2</sub>
	AB <sub>5</sub>	5	-	 <p>Trigonal bipyramida</p>	 <p>Trigonal bipyramida</p>	PCl <sub>5</sub> , ASF <sub>5</sub> , SOF <sub>4</sub>
	AB <sub>4</sub> L	4	1	 <p>Seesaw</p>	 <p>Seesaw</p>	SF <sub>4</sub> , XeO <sub>2</sub> F <sub>2</sub> , IF <sub>4</sub> <sup>+</sup> , IO <sub>2</sub> F <sub>2</sub>

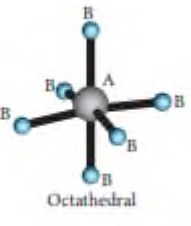
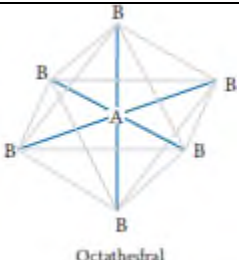
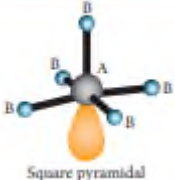
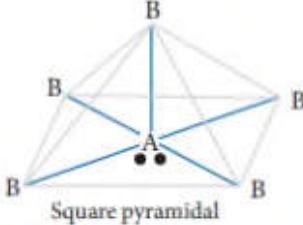
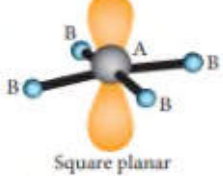
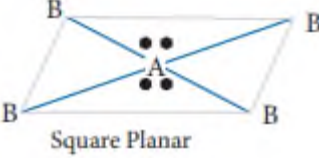
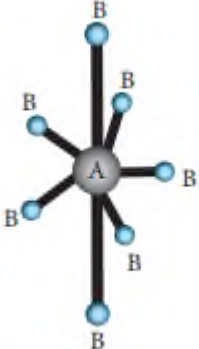
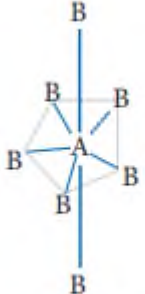
5	$AB_3L_2$	3	2	 <p>T shaped</p>	 <p>T Shaped</p>	$BrF_3, ClF_3,$
	$AB_2L_3$	2	3	 <p>Linear</p>	 <p>Linear</p>	$XeF_2, I_3^-, IF_2^-$
	$AB_6$	6	-	 <p>Octahedral</p>	 <p>Octahedral</p>	$SF_6, IOF_5,$
6	$AB_5L$	5	1	 <p>Square pyramidal</p>	 <p>Square pyramidal</p>	$BrF_5, IF_5, TeF_5^-, XeOF_4,$
	$AB_4L_2$	4	2	 <p>Square planar</p>	 <p>Square Planar</p>	$XeF_4, ICl_4^-$
7	$AB_7$	7	-		 <p>pentagonal bi-pyramidal</p>	$IF_7$



## Valence Bond Theory

Heitler and London gave a theoretical treatment to explain the formation of covalent bond in hydrogen molecule on the basis of wave mechanics of electrons. It was further developed by Pauling and Slater. The wave mechanical treatment of VB theory is beyond the scope of this textbook. A simple qualitative treatment of VB theory for the formation of hydrogen molecule is discussed below.

Consider a situation wherein two hydrogen atoms ( $H_a$  and  $H_b$ ) are separated by infinite distance. At this stage there is no interaction between these two atoms and the potential energy of this system is arbitrarily taken as zero. As these two atoms approach each other, in addition to the electrostatic attractive force between the nucleus and its own electron (purple arrows), the following new forces begins to operate.

### VB theory for the formation of hydrogen molecule

The new attractive forces (green arrows) arise between

- (i) nucleus of  $H_a$  and valence electron of  $H_b$
- (ii) nucleus of  $H_b$  and the valence electron of  $H_a$ .

The new repulsive forces (red arrows) arise between

- (i) the nucleus of  $H_a$  and  $H_b$
- (ii) valence electrons of  $H_a$  and  $H_b$ .

The attractive forces tend to bring  $H_a$  and  $H_b$  together whereas the repulsive forces tends to push them apart. At the initial stage, as the two hydrogen atoms approach each other, the attractive forces are stronger than the repulsive forces and the potential energy decreases. A stage is reached where the net attractive forces are exactly balanced by repulsive forces and the potential energy of the system acquires a minimum energy.

### VB theory for the formation of hydrogen molecule

At this stage, there is a maximum overlap between the atomic orbitals of  $H_a$  and  $H_b$ , and the atoms  $H_a$  and  $H_b$  are now said to be bonded together by a covalent bond. The internuclear distance at this stage gives the H-H bond length and is equal to 74 pm. The liberated energy is 436 kJ mol<sup>-1</sup> and is known as bond energy. Since the energy is released during the bond formation, the resultant molecule is more stable. If the distance between the two atoms is decreased further, the repulsive forces dominate the attractive forces and the potential energy of the system sharply increases

### Salient features of VB Theory:

- (i) When half filled orbitals of two atoms overlap, a covalent bond will be formed between them.
- (ii) The resultant overlapping orbital is occupied by the two electrons with opposite spins. For example, when H<sub>2</sub> is formed, the two 1s electrons of two hydrogen atoms get paired up and occupy the overlapped orbital.
- (iii) The strength of a covalent bond depends upon the extent of overlap of atomic orbitals. Greater the overlap, larger is the energy released and stronger will be the bond formed.
- (iv) Each atomic orbital has a specific direction (except s-orbital which is spherical) and hence orbital overlap takes place in the direction that maximizes overlap

Let us explain the covalent bond formation in hydrogen, fluorine and hydrogen fluoride using VB theory.

### Orbital Overlap

When atoms combine to form a covalent molecule, the atomic orbitals of the combining atoms overlap to form a covalent bond. The bond pair of electrons will occupy the overlapped region of the orbitals. Depending upon the nature of overlap we can classify the covalent bonding between the two atoms as sigma ( $\sigma$ ) and pi ( $\pi$ ) bonds.

### Sigma and Pi bonds

When two atomic orbitals overlap linearly along the axis, the resultant bond is called a sigma ( $\sigma$ ) bond. This overlap is also called 'head-on overlap' or 'axial overlap'. Overlap involving an s orbital (s-s and s-p overlaps) will always result in a sigma bond as the s orbital is spherical. Overlap between two p orbitals along the molecular axis will also result in sigma bond formation. When we consider x-axis as molecular axis, the p<sub>x</sub>-p<sub>x</sub> overlap will result in  $\sigma$ -bond.

When two atomic orbitals overlap sideways, the resultant covalent bond is called a pi ( $\pi$ ) bond. When we consider x-axis as molecular axis, the p<sub>y</sub>-p<sub>y</sub> and p<sub>z</sub>-p<sub>z</sub> overlaps will result in the formation of a  $\pi$ -bond.

Following examples will be useful to understand the overlap:

### Formation of hydrogen (H<sub>2</sub>) Molecule

Electronic configuration of hydrogen atom is 1s<sup>1</sup>

During the formation of  $H_2$  molecule, the  $1s$  orbitals of two hydrogen atoms containing one unpaired electron with opposite spin overlap with each other along the internuclear axis. This overlap is called s-s overlap. Such axial overlap results in the formation of a  $\sigma$ -covalent bond.

### Formation of hydrogen molecule

Formation of fluorine molecule ( $F_2$ ):

Valence shell electronic configuration of fluorine atom:  $2s^2 2p_x^2, 2p_y^2, 2p_z^1$

When the half filled  $p_z$  orbitals of two fluorine overlaps along the z-axis, a  $\sigma$ -covalent bond is formed between them.

### Formation of $F_2$ Molecule

**Formation of HF molecule:**

Electronic configuration of hydrogen atom is  $1s^1$

Valence shell electronic configuration of fluorine atom:  $2s^2 2p_x^2, 2p_y^2, 2p_z^1$

When half filled  $1s$  orbital of hydrogen linearly overlaps with a half filled  $2p_z$  orbital of fluorine, a  $\sigma$ -covalent bond is formed between hydrogen and fluorine.

### Formation of HF Molecule

**Formation of oxygen molecule ( $O_2$ ):**

Valence shell electronic configuration of oxygen atom:  $2s^2 2p_x^2, 2p_y^1, 2p_z^1$

When the half filled  $p_z$  orbitals of two oxygen overlaps along the z-axis (considering molecular axis as z axis), a  $\sigma$ -covalent bond is formed between them. Other two half filled  $p_y$  orbitals of two oxygen atoms overlap laterally (sideways) to form a  $\pi$ -covalent bond between the oxygen atoms. Thus, in oxygen molecule, two oxygen atoms are connected by two covalent bonds (double bond). The other two pair of electrons present in the  $2s$  and  $2p_x$  orbital do not involve in bonding and remains as lone pairs on the respective oxygen.

### Formation of $\pi$ bond in $O_2$ Molecule

### Hybridisation

Bonding in simple molecules such as hydrogen and fluorine can easily be explained on the basis of overlap of the respective atomic orbitals of the combining atoms. But the observed properties of polyatomic molecules such as methane, ammonia, beryllium chloride etc...cannot be explained on the basis of simple overlap of atomic orbitals. For example, it was experimentally proved that methane has a tetrahedral structure and the four C-H bonds are equivalent. This fact cannot be explained on the basis of overlap of atomic orbitals of hydrogen (1s) and the atomic orbitals of carbon with different energies ( $2s^2 2p_x^2 2p_y 2p_z$ ).

In order to explain these observed facts, Linus Pauling proposed that the valence atomic orbitals in the molecules are different from those in isolated atom and he introduced the concept of hybridisation. Hybridisation is the process of mixing of atomic orbitals of the same atom with comparable energy to form equal number of new equivalent orbitals with same energy. The resultant orbitals are called hybridised orbitals and they possess maximum symmetry and definite orientation in space so as to minimize the force of repulsion between their electrons.

### Types of hybridisation and geometry of molecules

#### sp Hybridisation:

Consider the bond formation in beryllium chloride. The ground state valence shell electronic configuration of Beryllium atom is  $[\text{He}] 2s^2 2p^0$

In  $\text{BeCl}_2$  both the Be-Cl bonds are equivalent and it was observed that the molecule is linear. VB theory explains this observed behaviour by sp hybridisation. One of the paired electrons in the 2s orbital gets excited to 2p orbital and the electronic configuration at the excited state is shown.

Now, the 2s and 2p orbitals hybridise and produce two equivalent sp hybridised orbitals which have 50 % s-character and 50 % p-character. These sp hybridised orbitals are oriented in opposite direction as shown in the figure.

#### Overlap with orbital of chlorine

Each of the sp hybridized orbitals linearly overlap with  $3p_z$  orbital of the chlorine to form a covalent bond between Be and Cl as shown in the Figure.

#### sp Hybridisation : $\text{BeCl}_2$

#### sp<sup>2</sup> Hybridisation:

Consider the bond formation in boron trifluoride. The ground state valence shell electronic configuration of Boron atom is  $[\text{He}] 2s^2 2p^1$ .

In the ground state boron has only one unpaired electron in the valence shell. In order to form three covalent bonds with fluorine atoms, three unpaired electrons are required. To achieve this, one of the paired electrons in the 2s orbital is promoted to the  $2p_y$  orbital in the excited state.

In boron, the s orbital and two p orbitals ( $p_x$  and  $p_y$ ) in the valence shell hybridise, to generate three equivalent  $sp^2$  orbitals as shown in the Figure. These three orbitals lie in the same xy plane and the angle between any two orbitals is equal to  $120^\circ$ .

#### Overlap with $2p_z$ orbitals of fluorine:

The three  $sp^2$  hybridised orbitals of boron now overlap with the  $2p_z$  orbitals of fluorine (3 atoms). This overlap takes place along the axis as shown below.

#### $sp^3$ Hybridisation:

$sp^3$  hybridisation can be explained by considering methane as an example. In methane molecule the central carbon atom is bound to four hydrogen atoms. The ground state valence shell electronic configuration of carbon is  $[\text{He}] 2s^2 2p_x^1 2p_y^1 2p_z^0$ .

In order to form four covalent bonds with the four hydrogen atoms, one of the paired electrons in the 2s orbital of carbon is promoted to its  $2p_z$  orbital in the excited state. The one 2s orbital and the three 2p orbitals of carbon mix to give four equivalent  $sp^3$  hybridised orbitals. The angle between any two  $sp^3$  hybridised orbitals is  $109^\circ 28'$ .

#### Overlap with 1s orbitals of hydrogen:

The 1s orbitals of the four hydrogen atoms overlap linearly with the four  $sp^3$  hybridised orbitals of carbon to form four C-H  $\sigma$ -bonds in the methane molecule, as shown below.

#### $sp^3$ Hybridisation : $\text{CH}_4$

#### $sp^3d$ Hybridisation:

In the molecules such as  $\text{PCl}_5$ , the central atom phosphorus is covalently bound to five chlorine atoms. Here the atomic orbitals of phosphorus undergo  $sp^3d$  hybridisation which involves its one 3s orbital, three 3p orbitals and one vacant 3d orbital ( $d_{z^2}$ ). The ground state electronic configuration of phosphorus is  $[\text{Ne}] 3s^2 3p_x^1 3p_y^1 3p_z^1$  as shown below.

One of the paired electrons in the 3s orbital of phosphorous is promoted to one of its vacant 3d orbital ( $d_{z^2}$ ) in the excited state. One 3s orbital, three 3p orbitals and one  $3d_{z^2}$  orbital of phosphorus atom mixes to give five equivalent  $sp^3d$  hybridised orbitals. The orbital geometry of  $sp^3d$  hybridised orbitals is trigonal bipyramidal as shown in the figure

#### Overlap with $3p_z$ orbitals of chlorine:

The  $3p_z$  orbitals of the five chlorine atoms linearly overlap along the axis with the five  $sp^3d$  hybridised orbitals of phosphorous to form the five P-Cl  $\sigma$ -bonds, as shown below.

#### $sp^3d$ Hybridisation : $PCl_5$

#### $sp^3d^2$ Hybridisation:

In sulphur hexafluoride ( $SF_6$ ) the central atom sulphur extends its octet to undergo  $sp^3d^2$  hybridisation to generate six  $sp^3d^2$  hybridised orbitals which accounts for six equivalent S-F bonds. The ground state electronic configuration of sulphur is  $[Ne]3s^2 3p_x^2 3p_y^1 3p_z^1$ .

One electron each from 3s orbital and 3p orbital of sulphur is promoted to its two vacant 3d orbitals ( $d_{z^2}$  and  $d_{x^2-y^2}$ ) in the excited state. A total of six valence orbitals from sulphur (one 3s orbital, three 3p orbitals and two 3d orbitals) mixes to give six equivalent  $sp^3d^2$  hybridised orbitals. The orbital geometry is octahedral as shown in the figure.

#### Overlap with $2p_z$ orbitals of fluorine:

The six  $sp^3d^2$  hybridised orbitals of sulphur overlap linearly with  $2p_z$  orbitals of six fluorine atoms to form the six S-F bonds in the sulphur hexafluoride molecule.

#### $sp^3d^2$ Hybridisation : $SF_6$

#### Bonding in Ethylene:

The bonding in ethylene can be explained using hybridisation concept. The molecular formula of ethylene is  $C_2H_4$ . The valency of carbon is 4. The electronic configuration of valence shell of carbon in ground state is  $[He] 2s^2 2p_x^1 2p_y^1 2p_z^0$ . To satisfy the valency of carbon promote an electron from 2s orbital to  $2p_z$  orbital in the excited state.

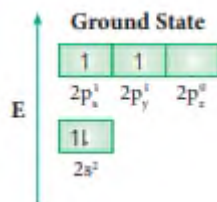

In ethylene both the carbon atoms undergoes  $sp^2$  hybridisation involving  $2s$ ,  $2p_x$  and  $2p_y$  orbitals, resulting in three equivalent  $sp^2$  hybridised orbitals lying in the  $xy$  plane at an angle of  $120^\circ$  to each other. The unhybridised  $2p_z$  orbital lies perpendicular to the  $xy$  plane.

### Formation of sigma bond:

One of the  $sp^2$  hybridised orbitals of each carbon lying on the molecular axis ( $x$ -axis) linearly overlaps with each other resulting in the formation a C-C sigma bond. Other two  $sp^2$  hybridised orbitals of both carbons linearly overlap with the four  $1s$  orbitals of four hydrogen atoms leading to the formation of two C-H sigma bonds on each carbon.

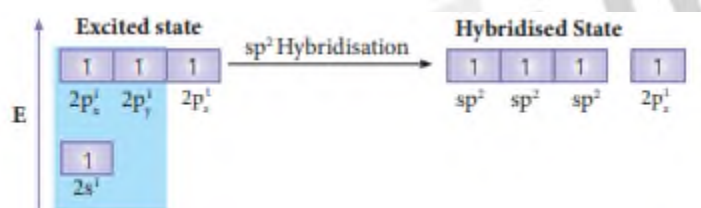

### Formation of Pi ( $\pi$ ) bond:

The unhybridised  $2p_z$  orbital of both carbon atoms can overlap only sideways as they are not in the molecular axis. This lateral overlap results in the formation a pi ( $\pi$ ) bond between the two carbon atoms as shown in the figure.

### $sp^2$ Hybridisation : $C_2H_4$

### Bonding in acetylene:

Similar to ethylene, the bonding in acetylene can also be explained using hybridisation concept. The molecular formula of acetylene is  $C_2H_2$ . The electronic configuration of valence shell of carbon in ground state is  $[He] 2s^2 2p_x^1 2p_y^1 2p_z^0$ . To satisfy the valency of carbon promote an electron from  $2s$  orbital to  $2p_z$  orbital in the excited state.

In acetylene molecule, both the carbon atoms are in  $sp$  hybridised state. The  $2s$  and  $2p_x$  orbitals, resulting in two equivalent  $sp$  hybridised orbitals lying in a straight line along the molecular axis ( $x$ -axis). The unhybridised  $2p_y$  and  $2p_z$  orbitals lie perpendicular to the molecular axis.

### Formation of sigma bond:

One of the two sp hybridised orbitals of each carbon linearly overlaps with each other resulting in the formation of a C-C sigma bond. The other sp hybridised orbital of both carbons linearly overlaps with the two 1s orbitals of two hydrogen atoms leading to the formation of one C-H sigma bond on each carbon.

### Formation of pi bond:

The unhybridised  $2p_y$  and  $2p_z$  orbitals of each carbon overlap sideways. This lateral overlap results in the formation of two pi bonds ( $p_y - p_y$  and  $p_z - p_z$ ) between the two carbon atoms as shown in the figure.

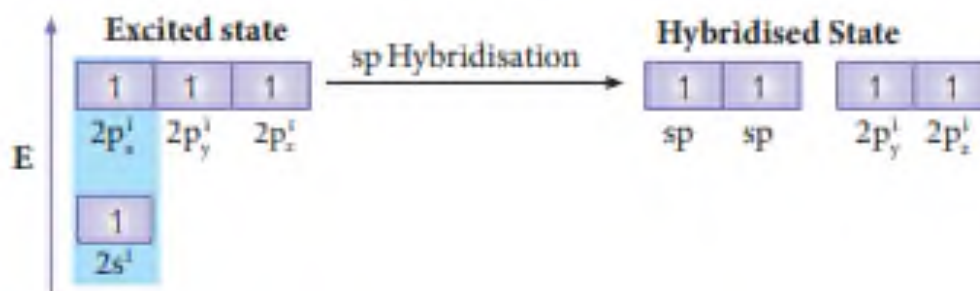

### Sp Hybridisation in acetylene: $C_2H_2$

#### Molecular orbital theory

Lewis concept and valence bond theory qualitatively explain the chemical bonding and molecular structure. Both approaches are inadequate to describe some of the observed properties of molecules. For example, these theories predict that oxygen is diamagnetic. However, it was observed that oxygen in liquid form was attracted towards the poles of a strong magnet, indicating that oxygen is paramagnetic. As both these theories treated the bond formation in terms of electron pairs and hence they fail to explain the bonding nature of paramagnetic molecules. F. Hund and Robert S. Mulliken developed a bonding theory called molecular orbital theory which explains the magnetic behaviour of molecules.

#### The salient features of Molecular orbital Theory (MOT):

1. When atoms combine to form molecules, their individual atomic orbitals lose their identity and form new orbitals called molecular orbitals.
2. The shapes of molecular orbitals depend upon the shapes of combining atomic orbitals.
3. The number of molecular orbitals formed is the same as the number of combining atomic orbitals. Half the number of molecular orbitals formed will have lower energy than the corresponding atomic orbital, while the remaining molecular orbitals will have higher energy. The molecular orbital with lower energy is called bonding



molecular orbital and the one with higher energy is called anti-bonding molecular orbital. The bonding molecular orbitals are represented as  $\sigma$  (Sigma),  $\pi$  (pi),  $\delta$  (delta) and the corresponding antibonding orbitals are denoted as  $\sigma^*$ ,  $\pi^*$  and  $\delta^*$ .

4. The electrons in a molecule are accommodated in the newly formed molecular orbitals. The filling of electrons in these orbitals follows Aufbau's principle, Pauli's exclusion principle and Hund's rule as in the case of filling of electrons in atomic orbitals.
5. Bond order gives the number of covalent bonds between the two combining atoms. The bond order of a molecule can be calculated using the following equation

$$\text{Bond order} = \frac{N_b - N_a}{2}$$

Where,

$N_b$  = Total number of electrons present in the bonding molecular orbitals  
 $N_a$  = Total number of electrons present in the antibonding molecular orbitals and  
 A bond order of zero value indicates that the molecule doesn't exist.

### Linear combination of atomic orbitals

The wave functions for the molecular orbitals can be obtained by solving Schrödinger wave equation for the molecule. Since solving the Schrödinger equation is too complex, approximation methods are used to obtain the wave function for molecular orbitals. The most common method is the linear combination of atomic orbitals (LCAO).

We know that the atomic orbitals are represented by the wave function  $\Psi$ . Let us consider two atomic orbitals represented by the wave function  $\psi_A$  and  $\psi_B$  with comparable energy, combines to form two molecular orbitals. One is bonding molecular orbital ( $\psi$  bonding) and the other is antibonding molecular orbital ( $\psi$  antibonding). The wave functions for these two molecular orbitals can be obtained by the linear combination of the atomic orbitals  $\psi_A$  and  $\psi_B$  as below.

$$\begin{aligned}\Psi_{\text{bonding}} &= \psi_A + \psi_B \\ \Psi_{\text{antibonding}} &= \psi_A - \psi_B\end{aligned}$$

The formation of bonding molecular orbital can be considered as the result of constructive interference of the atomic orbitals and the formation of anti-bonding molecular orbital can be the result of the destructive interference of the atomic orbitals. The formation of the two molecular orbitals from two 1s orbitals is shown below  
 Constructive interaction:  
 The two 1s orbitals are in phase and have the same sign.

### Destructive interaction The two 1s Orbitals are out phase

## Linear Combination of atomic orbitals

### Metallic bonding

Metals have some special properties of lustre, high density, high electrical and thermal conductivity, malleability and ductility, and high melting and boiling points. The forces that keep the atoms of the metal so closely in a metallic crystal constitute what is generally known as the metallic bond. The metallic bond is not just an electrovalent bond (ionic bond), as the latter is formed between atoms of different electro negativities. Similarly, the metallic bond is not a covalent bond, as the metal atoms do not have sufficient number of valence electrons for mutual sharing with 8 or 12 neighboring metal atoms in a crystal. So, we have to search for a new theory to explain metallic bond. The first successful theory is due to Drude and Lorentz, which regards metallic crystal as an assemblage of positive ions immersed in a gas of free electrons. The free electrons are due to ionization of the valence electrons of the atoms of the metal. As the valence electrons of the atoms are freely shared by all the ions in the crystal, the metallic bonding is also referred to as electronic bonding. As the free electrons repel each other, they are uniformly distributed around the metal ions. Many physical properties of the metals can be explained by this theory, nevertheless there are exceptions.

The electrostatic attraction between the metal ions and the free electrons yields a three-dimensional close packed crystal with a large number of nearest metal ions. So, metals have high density. As the close packed structure contains many slip planes along which movement can occur during mechanical loading, the metal acquires ductility. Pure metals can undergo 40 to 60% elongation prior to rupturing under mechanical loading. As each metal ion is surrounded by electron cloud in all directions, the metallic bonding has no directional properties.

As the electrons are free to move around the positive ions, the metals exhibit high electrical and thermal conductivity. The metallic luster is due to reflection of light by the electron cloud. As the metallic bond is strong enough, the metal atoms are reluctant to break apart into a liquid or gas, so the metals have high melting and boiling points.

The bonding in metal is better treated by Molecular orbital theory. As per this theory, the atomic orbitals of large number of atoms in a crystal overlap to form numerous bonding and antibonding molecular orbitals without any band gap. The bonding molecular orbitals are completely filled with an electron pair in each, and the antibonding molecular orbitals are empty. Absence of band gap accounts for high electrical conductivity of metals. High thermal conductivity is due to thermal excitation of many electrons from the valence band to the conductance band. With an increase in temperature, the electrical conductivity decreases due to vigorous thermal motion of lattice ions that disrupts the uniform lattice structure, that is required for free motion of electrons within the crystal. Most metals are black except copper, silver and gold. It is due to absorption of light of all wavelengths. Absorption of light of all wavelengths is due to absence of bandgap in metals.

## UNIT - 15 - Environmental Chemistry

### Environmental Pollution

Any undesirable change in our environment that has harmful effects on plants, animals and human beings is called environmental pollution.

Environmental pollution is usually caused by the addition of waste products of human activity to the environment. The substances which cause pollution of environment are called pollutants. The pollutants may be solids, liquids or gaseous substances present in significant concentration in the environment. Our environment becomes polluted day by day, by the increased addition of industrial and domestic wastes to it. The air we breathe, the water we drink and the place where we live in, are highly contaminated.

The pollutants are classified as bio-degradable and non-biodegradable pollutants.

#### i. Bio-degradable pollutants :

The pollutants which can be easily decomposed by the natural biological processes are called bio-degradable pollutants. Examples: plant wastes, animal wastes etc.

#### ii. Non bio-degradable pollutants :

The pollutants which cannot be decomposed by the natural biological processes are called Non bio-degradable pollutants. Examples: metal wastes (mainly Hg and Pb), D.D.T, plastics, nuclear wastes etc., These pollutants are harmful to living organisms even in low concentration. As they are not degraded naturally, it is difficult to eliminate them from our environment.

### Atmospheric Pollution

Earth's atmosphere is a layer of gases retained by the earth's gravity. It contains roughly 78% nitrogen, 21% oxygen, 0.93% argon, 0.04% carbon dioxide, trace amounts of other gases and little amount of water vapour. This mixture is commonly known as air.

Earth's atmosphere can be divided into different layers with characteristic altitude and temperature. The various regions of atmosphere are given in table 15.1.

Region	Altitude from earth's surface	Temperature range	Gases/ species present
Troposphere		15° C to -56°C	N <sub>2</sub> O <sub>2</sub>

	0-10 km		CO <sub>2</sub> H <sub>2</sub> O (vap)
Stratosphere (ozonosphere)	10-50 km	-56°C to -2°C	N <sub>2</sub> O <sub>2</sub> O <sub>3</sub> O atoms
Mesosphere	50-85 km	-2°C to -92°C	N <sub>2</sub> O <sup>2+</sup> NO <sup>+</sup>
Thermosphere	85- 500 km	-92°C to 1200°C	O <sub>2</sub> <sup>+</sup> O <sup>+</sup> NO <sup>+</sup> e <sup>-</sup>

### Troposphere :

The lowest layer of the atmosphere is called the troposphere and it extends from 0 - 10 km from the earth surface. About 80% of the mass of the atmosphere is in this layer. This troposphere is further divided as follows.

#### i) Hydrosphere:

Hydrosphere includes all types of water sources like oceans, seas, rivers, lakes, streams, underground water, polar icecaps, clouds etc. It covers about 75% of the earth's surface. Hence the earth is called as a blue planet.

#### ii) Lithosphere:

Lithosphere includes soil, rocks and mountains which are solid components of earth.

#### iii) Biosphere:

It includes the lithosphere hydrosphere and atmosphere integrating the living organism present in the lithosphere, hydrosphere and atmosphere.

### The Bhopal Tragedy

The world's worst chemical disaster happened in the Indian city of Bhopal in the early morning hours of December 3, 1984. An explosion at the Union Carbide pesticide plant released a cloud of toxic gas (methyl isocyanate)  $\text{CH}_3\text{NCO}$  into the air. Since the gas was twice as heavy as air, it did not drift away but formed a 'blanket' over the surrounding area. It attacked people's lungs and affected their breathing. Thousands of people died and the lives of many were ruined. The lungs, brain, eyes, muscles as well as gastrointestinal, neurological and immune systems of those who survived were severely affected.

### Types of environmental pollution

Atmospheric pollution is generally studied as tropospheric pollution. Different types of atmospheric pollutions are

- (1) Air pollution
- (2) Water pollution
- (3) Soil pollution.

### Air pollution

Any undesirable change in air which adversely affects living organisms is called air pollution. Air pollution is limited to troposphere and stratosphere. Air pollution is mainly due to the excessive discharge of undesirable foreign matter into the atmospheric air.

### Types of air pollutants

Air pollutants may exist in two major forms namely, gases and particulates.

### Gaseous air pollutants

Oxides of sulphur, oxides of nitrogen, oxides of carbon, and hydrocarbons are the gaseous air pollutants.

#### a. Oxides of Sulphur

Sulphur dioxide and sulphur trioxide are produced by burning sulphur containing fossil fuels and roasting sulphide ores. Sulphur dioxide is a poisonous gas to both animals and plants. Sulphur dioxide causes eye irritation, coughing and respiratory diseases like asthma, bronchitis, etc.

Sulphur dioxide is oxidised into more harmful sulphur trioxide in the presence of particulate matter present in polluted air .

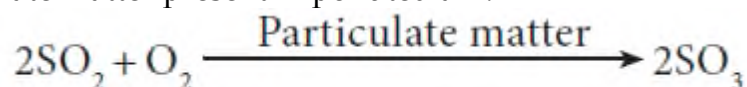

$\text{SO}_3$  combines with atmospheric water vapour to form  $\text{H}_2\text{SO}_4$  , which comes down in the form of acid rain.



Some harmful effects of acid rain will be discussed in section 15.3

### b. Oxides of nitrogen

Oxides of nitrogen are produced during high temperature combustion processes, oxidation of nitrogen in air and from the combustion of fuels (coal, diesel, petrol etc.).

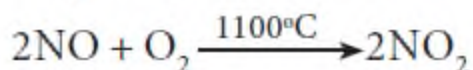
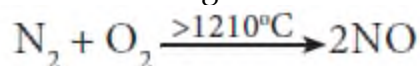

The oxides of nitrogen are converted into nitric acid which comes down in the form of acid rain. They also form reddish brown haze in heavy traffic. Nitrogen dioxide potentially damages plant leaves and retards photosynthesis.  $\text{NO}_2$  is a respiratory irritant and it can cause asthma and lung injury. Nitrogen dioxide is also harmful to various textile fibres and metals.

### c. Oxides of carbon

The major pollutants of oxides of carbon are carbon monoxide and carbon dioxide.

#### (i) Carbon Monoxide

Carbon monoxide is a poisonous gas produced as a result of incomplete combustion of coal and firewood. It is released into the air mainly by automobile exhaust. It binds with haemoglobin and forms carboxy haemoglobin which impairs normal oxygen transport by blood and hence the oxygen carrying capacity of blood is reduced. This oxygen deficiency results in headache, dizziness, tension, loss of consciousness, blurring of eye sight and cardiac arrest.

#### (ii) Carbon dioxide

Carbon dioxide is released into the atmosphere mainly by the process of respiration, burning of fossil fuels, forest fire, decomposition of limestone in cement industry etc.

Green plants can convert  $\text{CO}_2$  gas in the atmosphere into carbohydrate and oxygen through a process called photosynthesis. The increased  $\text{CO}_2$  level in the atmosphere is responsible for global warming. It causes headache and nausea.

#### (d) Hydrocarbon

The compounds composed of carbon and hydrogen only are called hydrocarbons. They are mainly produced naturally (marsh gas) and also by incomplete combustion of automobile fuel.

They are potential cancer causing (carcinogenic) agents. For example, polynuclear aromatic hydrocarbons (PAH) are carcinogenic, they cause irritation in eyes and mucous membranes.

### **Greenhouse effect and Global warming:**

In 1987, Jean Baptiste Fourier a French mathematician and scientist coined the term "Greenhouse Effect" for trapping of heat in the atmosphere by certain gases. The earth's atmosphere allows most of the visible light from the Sun to pass through and reach Earth's surface. As Earth's surface is heated by sunlight, it radiates part of this energy back toward space as longer wavelengths (IR).

Some of the heat is trapped by  $\text{CH}_4$ ,  $\text{CO}_2$ , CFCs and water vapour present in the atmosphere. They absorb IR radiation and effectively block a large portion of earth's emitted radiation. The radiation thus absorbed is partly reemitted to earth's surface. Therefore, the earth's surface gets heated up by a phenomenon called greenhouse effect.

Thus Greenhouse effect may be defined as the heating up of the earth surface due to trapping of infrared radiations reflected by earth's surface by  $\text{CO}_2$  layer in the atmosphere". The heating up of earth through the greenhouse effect is called global warming.

Without the heating caused by the greenhouse effect, Earth's average surface temperature would be only about  $-18^\circ\text{C}$  ( $0^\circ\text{F}$ ). Although the greenhouse effect is a naturally occurring phenomenon, it is intensified by the continuous emission of greenhouse gases into the atmosphere.

During the past 100 years, the amount of carbon dioxide in the atmosphere increased by roughly 30 percent and the amount of methane more than doubled. If these trends continue, the average global temperature will increase which can lead to melting of polar ice caps and flooding of low lying areas. This will increase incidence of infectious diseases like dengue, malaria etc.

### **Acid Rain**

Rain water normally has a pH of 5.6 due to dissolution of atmospheric  $\text{CO}_2$  into it. Oxides of sulphur and nitrogen in the atmosphere may be absorbed by droplets of water that make up clouds and get chemically converted into sulphuric acid and nitric acid respectively as a results of pH of rain water drops to the level 5.6, hence it is called acid rain.

Acid rain is a by-product of a variety of sulphur and nitrogen oxides in the atmosphere. Burning of fossil fuels (coal and oil) in power stations, furnaces and petrol, diesel in motor engines produce sulphur dioxide and nitrogen oxides. The main contributors

of acid rain are SO<sub>2</sub> and NO<sub>2</sub>. They are converted into sulphuric acid and nitric acid respectively by the reaction with oxygen and water.

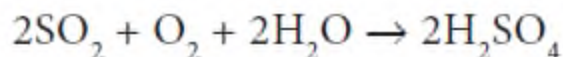

### Harmful effects of acid rain:

Some harmful effects are discussed below.

(i) Acid rain causes extensive damage to buildings and structural materials of marbles. This attack on marble is termed as Stone leprosy.



ii) Acid rain affects plants and animal life in aquatic ecosystem.

(iii) It is harmful for agriculture, trees and plants as it dissolves and removes the nutrients needed for their growth.

(iv) It corrodes water pipes resulting in the leaching of heavy metals such as iron, lead and copper into the drinking water which have toxic effects.

(v) It causes respiratory ailment in humans and animals.

### Particulate matter (Particulate pollutants)

Particulate pollutants are small solid particles and liquid droplets suspended in air. Many of particulate pollutants are hazardous. Examples: dust, pollen, smoke, soot and liquid droplets (aerosols) etc.,

They are blown into the atmosphere by volcanic eruption, blowing of dust, incomplete combustion of fossil fuels induces soot. Combustion of high ash fossil fuels creates fly ash and finishing of metals throws metallic particles into the atmosphere.

### Types of Particulates:

Particulate in the atmosphere may be of two types, viable or non-viable.

#### a. Viable particulates

The viable particulates are the small size living organisms such as bacteria, fungi, moulds, algae, etc. which are dispersed in air. Some of the fungi cause allergy in human beings and diseases in plants.

#### b. Non-viable particulates



The non-viable particulates are small solid particles and liquid droplets suspended in air. They help in the transportation of viable particles. There are four types of non-viable particulates in the atmosphere. They are classified according to their nature and size as follows

**(ii) Smoke**

Smoke particulate consists of solid particles (or) mixture of solid and liquid particles formed by combustion of organic matter.

For example, cigarette smoke, oil smoke, smokes from burning of fossil fuel, garbage and dry leaves.

**(ii) Dust:**

Dust composed of fine solid particles produced during crushing and grinding of solid materials. For example, sand from sand blasting, saw dust from wood works, cement dust from cement factories and fly ash from power generating units.

**(iii) Mists**

They are formed by particles of spray liquids and condensation of vapours in air.

For example, sulphuric acid mist, herbicides and insecticides sprays can form mists.

**(iv) Fumes**

Fumes are obtained by condensation of vapours released during sublimation, distillation, boiling and calcination and by several other chemical reactions.

For example, organic solvents, metals and metallic oxides form fume particles.

**Health effects of particulate pollutants:**

i. Dust, mist, fumes, etc., are air borne particles which are dangerous for human health. Particulate pollutants bigger than 5 microns are likely to settle in the nasal passage whereas particles of about 10 micron enter the lungs easily and cause scarring or fibrosis of lung lining. They irritate the lungs and cause cancer and asthma. This disease is also called pneumoconiosis. Coal miners may suffer from black lung disease. Textile workers may suffer from white lung disease.

ii. Lead particulates affect children's brain, interfere with maturation of RBCs and even cause cancer.

iii. Particulates in the atmosphere reduce visibility by scattering and absorption of sunlight. It is dangerous for aircraft and motor vehicles

iv. Particulates provide nuclei for cloud formation and increase fog and rain.

v. Particulates deposit on plant leaves and hinder the intake of CO<sub>2</sub> from the air and affect photosynthesis.

### **Techniques to reduce particulate pollutants**

The particulates from air can be removed by using electrostatic precipitators, gravity settling chambers, and wet scrubbers or by cyclone collectors. These techniques are based on washing away or settling of the particulates.

### **Smog**

Smog is a combination of smoke and fog which forms droplets that remain suspended in the air.

Smog is a chemical mixture of gases that forms a brownish yellow haze over urban cities. Smog mainly consists of ground level ozone, oxides of nitrogen, volatile organic compounds, SO<sub>2</sub>, acidic aerosols and gases, and particulate matter.

There are two types of smog. One is Classical smog caused by coal smoke and fog, second one is photo chemical smog caused by photo chemical oxidants. They are discussed below in detail.

#### **(i) Classical smog or London smog**

Classical smog was first observed in London in December 1952 and hence it is also known as London smog. It consists of coal smoke and fog.

It occurs in cool humid climate. This atmospheric smog found in many large cities. The chemical composition is the mixture of SO<sub>2</sub>, SO<sub>3</sub> and humidity. It generally occurs in the morning and becomes worse when the sun rises.

This is mainly due to the induced oxidation of SO<sub>2</sub> to SO<sub>3</sub>, which reacts with water yielding sulphuric acid aerosol.

Chemically it is reducing in nature because of high concentration of SO<sub>2</sub> and so it is also called as reducing smog.

#### **Effects of classical smog:**

- a. Smog is primarily responsible for acid rain.
- b. Smog results in poor visibility and it affects air and road transport.
- c. It also causes bronchial irritation.

#### **Great London Smog**

The great smog of London, or great smog of 1952, was a severe air-pollution event that affected the British capital of London in early December 1952. It lasted from Friday, 5 December to Tuesday, 9 December 1952 and then dispersed quickly when

the weather changed. It caused major disruption by reducing visibility and even penetrating indoor areas. Government medical reports in the following weeks, however, estimated that until 8 December, 4,000 people had died as a direct result of the smog and 100,000 more were made ill by the smog's effects on the human respiratory tract.

## ii) Photo chemical smog or Los Angel Smog

Photo Chemical smog was first observed in Los Angels in 1950. It occurs in warm, dry and sunny climate. This type of smog is formed by the combination of smoke, dust and fog with air pollutants like oxides of nitrogen and hydrocarbons in the presence of sunlight.

It forms when the sun shines and becomes worse in the afternoon. Chemically it is oxidizing in nature because of high concentration of oxidizing agents NO<sub>2</sub> and O<sub>3</sub>, so it is also called as oxidizing smog.

**Photo chemical smog is formed through sequence of following reactions.**

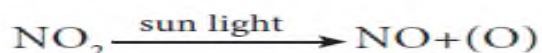
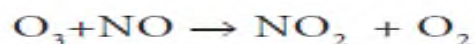
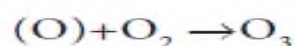
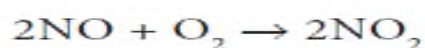
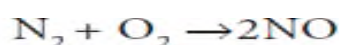

NO and O<sub>3</sub> are strong oxidizing agent and can react with unburnt hydrocarbons in polluted air to form formaldehyde, acrolein and peroxy acetyl nitrate (PAN).

### Effects of photo chemical smog

The three main components of photo chemical smog are nitrogen oxide, ozone and oxidised hydro carbon like formaldehyde (HCHO), Acrolein (CH<sub>2</sub>=CH-CHO), peroxy acetyl nitrate (PAN).

Photochemical smog causes irritation to eyes, skin and lungs, increase in chances of asthma.

High concentrations of ozone and NO can cause nose and throat irritation, chest pain, uncomfortable in breathing, etc.

PAN is toxic to plants, attacks younger leaves and cause bronzing and glazing of their surfaces. It causes corrosion of metals, stones, building materials and painted surfaces.

### Control of Photo chemical smog

The formation of photochemical smog can be suppressed by preventing the release of nitrogen oxides and hydrocarbons into the atmosphere from the motor vehicles by using catalytic converters in engines. Plantation of certain trees like Pinus, Pyrus, Quercus, Vitus and Juniperus can metabolise nitrogen oxide.

### Stratospheric pollution

At high altitudes the atmosphere consists of a layer of ozone (O<sub>3</sub>) which acts as an umbrella or shield for harmful UV radiations. It protects us from harmful effects such as skin cancer. UV radiation can convert molecular oxygen into ozone as shown in the following reaction.

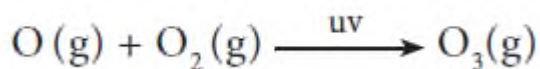
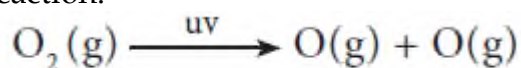

Ozone gas is thermodynamically unstable and readily decomposes to molecular oxygen.

### Depletion of Ozone Layer (Ozone hole)

In recent years, a gradual depletion of this protective ozone layer has been reported. Nitric oxide and CFC are found to be most responsible for depletion of ozone layer.

Generally substances that cause depletion of ozone or make it thinner are called Ozone Depletion Substances abbreviated as ODS. The loss of ozone molecules in the upper atmosphere is termed as depletion of stratospheric ozone.

### Oxides of Nitrogen:

Nitrogen oxides introduced directly into the stratosphere by the supersonic jet aircraft engines in the form of exhaust gases.

These oxides are also released by combustion of fossil fuels and nitrogen fertilizers. Inert nitrous oxide in the stratosphere is photochemically converted into more reactive nitric oxide. Oxides of nitrogen catalyse the decomposition of ozone and are themselves regenerated. Ozone gets depleted as shown below.

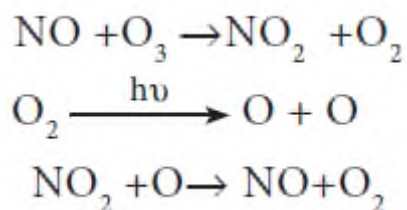

Thus NO is regenerated in the chain reaction.

### Chloro Fluoro Carbons (CFC) Freons

The chloro fluoro derivatives of methane and ethane are referred by trade name Freons. These Chloro Fluoro Carbon compounds are stable, non-toxic, noncorrosive and non-inflammable, easily liquefiable and are used in refrigerators, air-conditioners and in the production of plastic foams. CFC's are the exhaust of supersonic air craft's and jumbo jets flying in the upper atmosphere. They slowly pass from troposphere to stratosphere. They stay for very longer period of 50 - 100 years. In the presence of uv radiation, CFC's break up into chlorine free radical

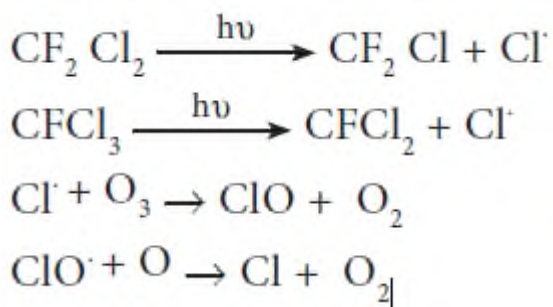

Chlorine radical is regenerated in the course of reaction. Due to this continuous attack of  $\text{Cl}^\cdot$  thinning of ozone layer takes place which leads to formation of ozone hole.

It is estimated that for every reactive chlorine atom generated in the stratosphere 1,00,000 molecules of ozone are depleted.

### Environmental Impact of Ozone Depletion

The formation and destruction of ozone is a regular natural process, which never disturbs the equilibrium level of ozone in the stratosphere. Any change in the equilibrium level of the ozone in the atmosphere will adversely affect life in the biosphere in the following ways.

Depletion of ozone layer will allow more UV rays to reach the earth surface and layer would cause skin cancer and also decrease the immunity level in human beings.

UV radiation affects plant proteins which leads to harmful mutation of cells.

UV radiation affects the growth of phytoplankton, as a result ocean food chain is disturbed and even damages the fish productivity.

### Water Pollution

Water is essential for life. Without water life would have been impossible. The slogan, 'Save Water, Water will save you' tell us the importance of water. Such slogans tell us to save water. Apart from saving water, maintaining its quality is also equally important.

Now a days water is getting polluted due to human activities and the availability of potable water in nature is becoming rare day by day. Water pollution is defined as "The addition of foreign substances or factors like heat which degrades the quality of water, so that it becomes health hazard or unfit to use."

The water pollutants originate from both natural and human activities. The source of water pollution is classified as Point and Non-point source.

Easily identified source of place of pollution is called as point source. Example: municipal and industrial discharge pipes.

Non-point source cannot be identified easily, example: agricultural runoff, mining wastes, acid rain, and storm-water drainage and construction sediments.

No	Pollutant	Sources
1	Microorganisms	Domestic sewage, domestic waste water, dung heap
2.	Organic wastes	Domestic sewage, animal excreta, food processing factory waste, detergents and decayed animals and plants,
3.	Plant nutrients	Chemical fertilisers
4.	Heavy metals	Heavy metal producing factories
5.	Sediments	Soil erosion by agriculture and strip-mining
6.	Pesticides	Chemicals used for killing insects, fungi and weeds
7.	Radioactive substances	Mining of uranium containing minerals
8.	Heat	Water used for cooling in industries

### Causes of water pollution

#### (i) Microbiological (Pathogens)

Disease causing microorganisms like bacteria, viruses and protozoa are most serious water pollutants.

They come from domestic sewage and animal excreta. Fish and shellfish can become contaminated and people who eat them can become ill. Some serious diseases like polio and cholera are water borne diseases. Human excreta contain bacteria such as *Escherichia coli* and *Streptococcus faecalis* which cause gastrointestinal diseases

### **(ii) Organic wastes:**

Organic matter such as leaves, grass, trash etc can also pollute water. Water pollution is caused by excessive phytoplankton growth within water.

Microorganisms present in water decompose these organic matter and consume dissolved oxygen in water.

### **Eutrophication:**

Eutrophication is a process by which water bodies receive excess nutrients that stimulates excessive plant growth (algae, other plant weeds). This enhanced plant growth in water bodies is called as algae bloom.

The growth of algae in extreme abundance covers the water surface and reduces the oxygen concentration in water. Thus, bloom-infested water inhibits the growth of other living organisms in the water body. This process in which the nutrient rich water bodies support a dense plant population, kills animal life by depriving it of oxygen and results in loss of biodiversity is known as eutrophication.

Biochemical oxygen demand (BOD)

The total amount of oxygen in milligrams consumed by microorganisms in decomposing the waste in one litre of water at 20°C for a period of 5 days is called biochemical oxygen demand (BOD) and its value is expressed in ppm.

BOD is used as a measure of degree of water pollution. Clean water would have BOD value less than 5 ppm whereas highly polluted water has BOD value of 17 ppm or more.

### **Chemical Oxygen Demand (COD)**

BOD measurement takes 5 days so another parameter called the Chemical Oxygen Demand (COD) is measured.

Chemical oxygen demand (COD) is defined as the amount of oxygen required by the organic matter in a sample of water for its oxidation by a strong oxidising agent like  $K_2Cr_2O_7$  in acid medium for a period of 2 hrs.

### **(iii) Chemical wastes:**

A whole variety of chemicals from industries, such as metals and solvents are poisonous to fish and other aquatic life.

Some toxic pesticides can accumulate in fish and shell fish and poison the people who eat them. Detergents and oils float and spoil the water bodies. Acids from mine drainage and salts from various sources can also contaminate water sources.

### Harmful effects of chemical water pollutants:

1. Cadmium and mercury can cause kidney damage.
2. Lead poisoning can leads to the severe damage of kidneys, liver, brain etc. it also affects central nervous system
3. Polychlorinated biphenyls (PCBs) causes skin diseases and are carcinogenic in nature.

### Quality of drinking water:

Now a days most of us hesitate to use natural water directly for drinking, because biological, physical or chemical impurities from different sources mix with surface water or ground water.

Institutions like WHO (World Health Organisation) at world level and BIS (Bureau of Indian Standards) and ICMR (ICMR: Indian Council of Medical Research) at national level have prescribed standards for quality of drinking water. Standard characteristics prescribed for deciding the quality of drinking water by BIS, in 1991 are shown in Table.15.3

### Standard characteristics of drinking water

S.No	Characteristics	Desirable limit
I	<b>Physico-chemical Characteristics</b>	
(i)	pH	6.5 to 8.5
(ii)	Total Dissolved Solids (TDS)	500 ppm
(iii)	Total Hardness (as CaCO <sub>3</sub> )	300 ppm
(iv)	Nitrate	45 ppm
(v)	Chloride	250 ppm
(vi)	Sulphate	200 ppm
(vii)	Fluoride	1 ppm
II	<b>Biological Characteristics</b>	



(i)	Escherichia Coli (E.Coli)	Not at all
(ii)	Coliforms	Not to exceed 10 (In 100 ml water sample)

### Fluoride:

Fluoride ion deficiency in drinking water causes tooth decay. Water soluble fluorides are added to increase the fluoride ion concentration upto 1 ppm.

The Fluoride ions make the enamel on teeth much harder by converting hydroxyapatite,

$[3(\text{Ca}_3(\text{PO}_4)_2 \cdot \text{Ca}(\text{OH})_2)]$ , the enamel on the surface of the teeth, into much harder fluorapatite,  $[3(\text{Ca}_3(\text{PO}_4)_2 \cdot \text{CaF}_2)]$ .

However, Fluoride ion concentration above 2 ppm causes brown mottling of teeth. Excess fluoride causes damage to bone and teeth.

### Lead :

Drinking water containing lead contamination above 50ppb can cause damage to liver, kidney and reproductive systems.

### Sulphate:

Moderate level of sulphate is harmless. Excessive concentration (>500ppm) of sulphates in drinking water causes laxative effect.

### Nitrate:

Use of drinking water having concentration of nitrate higher than 45 ppm may causes methemoglobinemia (blue baby syndrome) disease in children.

### Total dissolved solids (TDS):

Most of the salts are soluble in water. It includes cations like calcium, magnesium, sodium, potassium, iron and anions like carbonate, bicarbonate, chloride, sulphate, phosphate and nitrate. Use of drinking water having total dissolved solids concentration higher than 500 ppm causes possibilities of irritation in stomach and intestine.

### Soil Pollution

Soil is a thin layer of organic and inorganic material that covers the earth's rocky surface. Soil constitutes the upper crust of the earth, which supports land, plants and animals.

Soil pollution is defined as the buildup of persistent toxic compounds, radioactive materials, chemical salts and disease causing agents in soils which have harmful effects on plant growth and animal health.

Soil pollution affects the structure and fertility of soil, groundwater quality and food chain in biological ecosystem.

### **Sources of soil pollution**

The major sources of which pollute the soil are discussed below

#### **1) Artificial fertilizers:**

Soil nutrients are useful for growth of plants. Plants obtain carbon, hydrogen and oxygen from air or water, whereas other essential nutrients like nitrogen, phosphorus, potassium, calcium, magnesium, sulphur are being absorbed from soil. To remove the deficiency of nutrients in soil, farmers add artificial fertilizers. Increased use of phosphate fertilizers or excess use of artificial fertilizers like NPK in soil, results in reduced yield in that soil.

#### **2) Pesticides:**

Pesticides are the chemicals that are used to kill or stop the growth of unwanted organisms. But these pesticides can affect the health of human beings.

These are further classified as

##### **a. Insecticides:**

Insecticides like DDT, BHC, aldrin etc. can stay in soil for long period of time and are absorbed by soil. They contaminate root crops like carrot, radish, etc.

##### **b. Fungicide:**

Organic mercury compounds are used as most common fungicide. They dissociate in soil to produce mercury which is highly toxic.

##### **c. Herbicides:**

Herbicides are the chemical compounds used to control unwanted plants. They are otherwise known as weed killers. Example sodium chlorate ( $\text{NaClO}_3$ ) and sodium arsenite ( $\text{Na}_3\text{AsO}_3$ ). Most of the herbicides are toxic to mammals.

#### **3) Industrial wastes**

Industrial activities have been the biggest contributor to the soil pollution especially the mining and manufacturing activities.

Large number of toxic wastes are released from industries. Industrial wastes include cyanides, chromates, acids, alkalis, and metals like mercury, copper, zinc, cadmium and lead etc. These industrial wastes in the soil surface lie for a long time and make it unsuitable for use.

## Strategies to control environmental pollution

After studying air, water and soil pollution, as responsible individuals we must take responsibility to protect our environment. Think of steps which you would like to undertake for controlling environmental pollution not only in your locality but also in national and international level. We must realize about our environmental threat, focus strongly on this issues and be an eye opener to save our environment. We can think about following strategies to control environmental pollution.

1. Waste management: Environmental pollution can be controlled by proper disposal of wastes.
2. Recycling: a large amount of disposed waste material can be reused by recycling the waste, thus it reduces the land fill and converts waste into useful forms.
3. Substitution of less toxic solvents for highly toxic ones used in certain industrial processes.
4. Use of fuels with lower sulphur content (e.g., washed coal)
5. Growing more trees.
6. Control measures in vehicle emissions are adequate.

Efforts to control environmental pollution have resulted in development of science for synthesis of chemical favorable to environment and it is called green chemistry.

## Green Chemistry

Green chemistry is a chemical philosophy encouraging the design of products and processes that reduce or eliminate the use and generation of hazardous substances. For this, scientist are trying to develop methods to produce eco-friendly compounds. This can be best understood by considering the following example in which styrene is produced both by traditional and greener routes.

### Traditional route

This method involves two steps. Carcinogenic benzene reacts with ethylene to form ethyl benzene. Then ethyl benzene on dehydrogenation using  $\text{Fe}_2\text{O}_3/\text{Al}_2\text{O}_3$  gives styrene.

### Greener route

To avoid carcinogenic benzene, greener route is to start with cheaper and environmentally safer xylenes.

## Green chemistry in day-to-day life

A few contribution of green chemistry in our day to day life is given below

### (1) Dry cleaning of clothes

Solvents like tetrachloroethylene used in dry cleaning of clothes, pollute the ground water and are carcinogenic. In the place of tetrachloroethylene, liquefied  $\text{CO}_2$  with suitable detergent, is an alternate solvent used. Liquefied  $\text{CO}_2$  is not harmful

to the ground water. Now a days H<sub>2</sub>O<sub>2</sub> used for bleaching clothes in laundry, gives better results and utilizes less water.

## (2) Bleaching of paper

Conventional method of bleaching was done with chlorine. Now a days H<sub>2</sub>O<sub>2</sub> can be used for bleaching paper in presence of catalyst.

## (3) Synthesis of chemicals

Acetaldehyde is now commercially prepared by one step oxidation of ethene in the presence of ionic catalyst in aqueous medium with 90% yield.

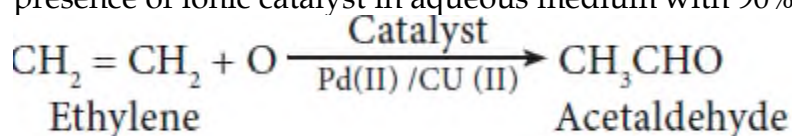

(4) Instead of petrol, methanol is used as a fuel in automobiles.

(5) Neem based pesticides have been synthesised, which are more safer than the chlorinated hydrocarbons.

Every individual has an important role for preventing pollution and improving our environment. We are responsible for environmental protection. Let us begin to save our environment and provide a clean earth for our future generations.